

EXPERIMENT Transformer Equivalent Circuit

Steady-State Testing and Performance of Single-Phase Transformers

OBJECTIVE

The voltage regulation and efficiency of a distribution system are affected by the electrical and magnetic characteristics of the transformers operating in the network. The design of such a distribution system must consider these effects. This experiment demonstrates the concept of open-circuit and short-circuit testing of transformers. From these tests, it is possible to determine the equivalent circuit of the transformer. The experiment also studies the excitation current, magnetization current, and core-loss current.

REFERENCES

1. “Electric Machinery”, Fourth Edition, Fitzgerald, Kinglsey, and Umans, McGraw-Hill Book Company, 1983, Chapter 1.
2. “Electromagnetic and Electromechanical Machines”, Matsch, Leander W., Intext Educational Publishers, 1972.
3. “Electromechanical Devices for Energy Conversion and Control Systems”, Del Toro, Vincent, Prentice-Hall, Inc., 1968.

BACKGROUND INFORMATION

The basic theory of transformer operation is adequately explained in Reference 1. For our purposes here we will concentrate on the test methods and the experimental set-up of Figure 2.

Figure 1 shows the traditionally accepted electrical equivalent circuit for a power transformer in steady-state. This particular equivalent circuit’s parameters are referred to side 1. All relevant impedances, voltages, and currents are shown in the figure.

Transformer Model

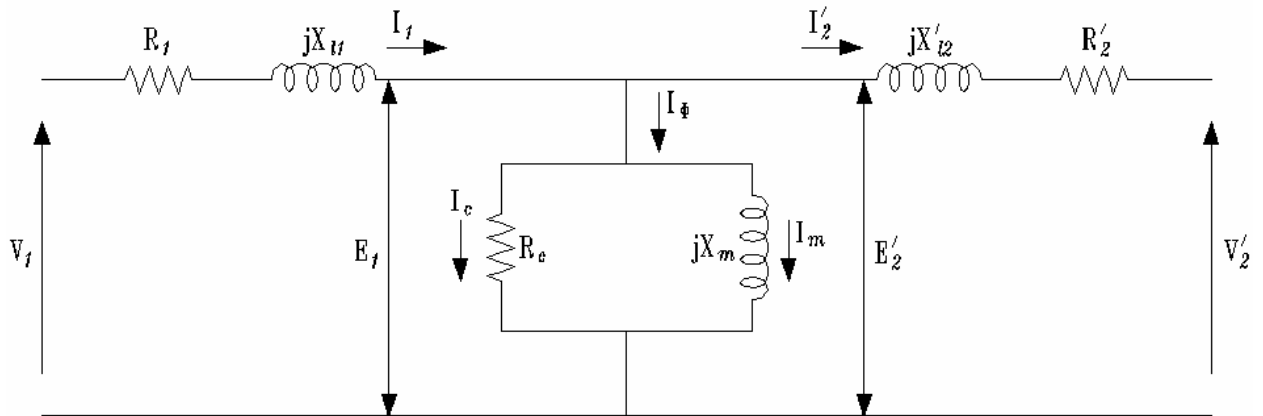

Figure 1: Steady-state equivalent circuit for power transformer.

It is important to note that for a typical power transformer the ratio of the parallel combination of the common leg impedances to the total impedance of either winding will exceed 200. Algebraically, this can be described as

$$\frac{|R_c // X_m|}{|R_1 + jX_{l1}|} > 200 \quad (2.1)$$

Figure 2 shows the experimental concept for the open-circuit and short-circuit tests. The open-circuit test is run at rated voltage and yields the following quantities;

I_{oc} = exciting current as read by ammeter A .

V_{oc} = applied voltage as read by voltmeter V .

P_{oc} = power as measured with wattmeter W .

Transformer Model

R_1 and X_{ℓ_1} are very small values, thus, their voltage drop is minimal. The voltage is small enough for us to assume that the open-circuit voltage V_{oc} appears across R_c and X_m , and that all power P_{oc} is dissipated by R_c . Therefore,

$$R_c = \frac{V_{oc}^2}{P_{oc}} \text{ ohms} \quad (2.2)$$

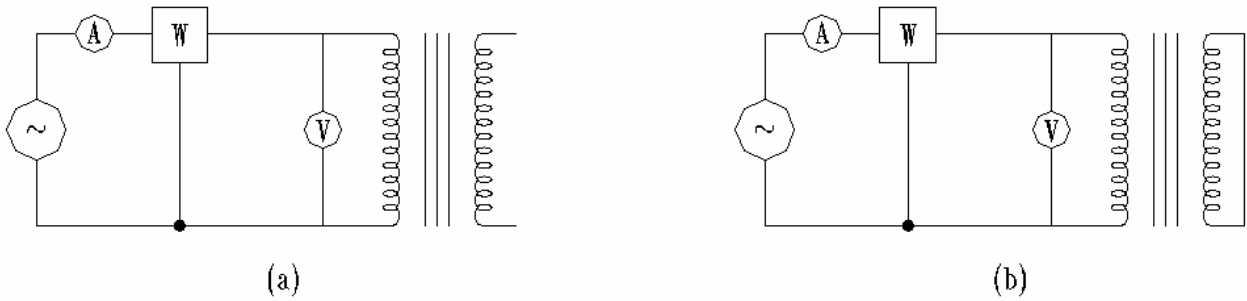

Figure 2: (a) Instrumentation for open-circuit test. (b) Instrumentation for short-circuit test.

The reactance X_m can be found by determining the reactive part of the test quantities.

Thus, the power factor is

$$\text{pf} = \frac{P_{oc}}{V_{oc} I_{oc}} \quad Q = \sqrt{S^2 - P^2} \quad (2.3)$$

and

$$I_m = I_{oc} \sin[\cos^{-1}(pf)] \quad (2.4)$$

from which

Transformer Model

$$X_m = \frac{V_{oc}}{I_m} = \frac{V_{oc}^2}{Q_{oc}} \quad \text{ohms} \quad (2.5)$$

The short-circuit test is run at rated current and provides the following information:

V_{sc} = applied voltage as read by voltmeter V

I_{sc} = input short-circuit current as read by ammeter A .

P_{sc} = input power as read by wattmeter W

Recalling Eq. 2.1, the equivalent impedance seen by the instruments is

$$Z_{eq} = (R_1 + R_2') + j(X_{\ell 1} + X_{\ell 2}') = R_{eq} + jX_{eq} = \frac{V_{sc}}{I_{sc}} \quad (2.6)$$

Since the parallel combination of the common leg impedance is very large, the majority of the input short-circuit current passes through only the winding impedances. Therefore, the core losses are negligible and the following is true:

$$R_{eq} = \frac{P_{sc}}{I_{sc}^2} \quad (2.7)$$

and

Transformer Model

$$X_{eq} = \sqrt{Z_{eg}^2 - R_{eg}^2}$$

$$R_1, R_2 = \frac{R_{eq}}{2} \qquad X_1, X_2 = \frac{X_{eq}}{2} \qquad (2.8)$$

In the absence of more definitive information, the components of R_{eq} and X_{eq} are split equally between the two sides of the transformer. This completes the development necessary to derive the steady-state equivalent circuit from the test data.

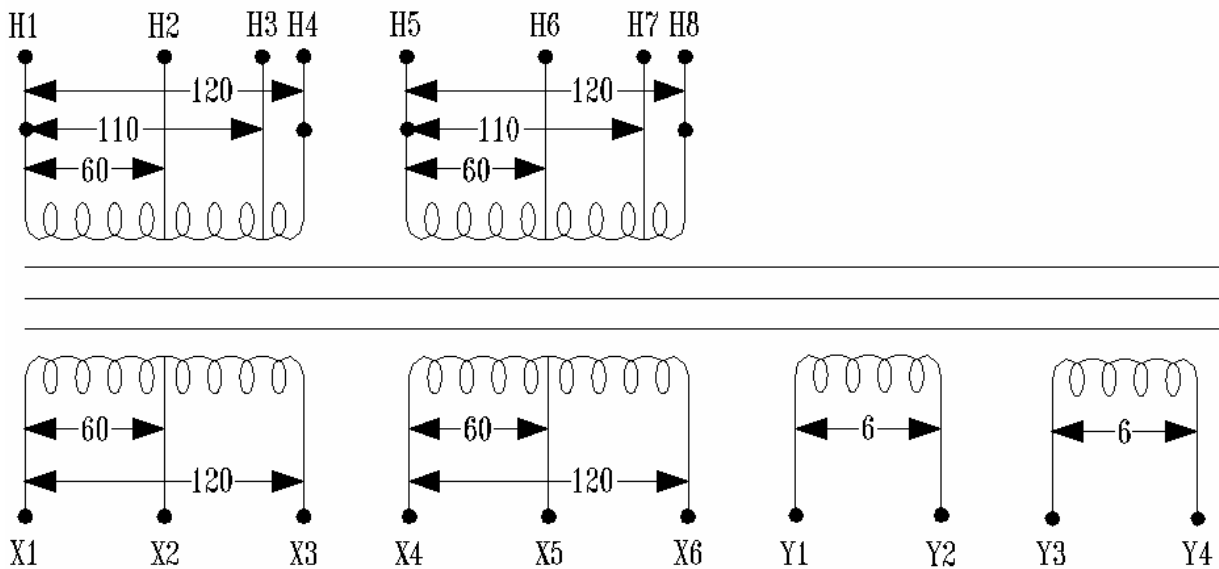

Figure 3: Winding configuration of laboratory transformers.

SUGGESTED PROCEDURE

The transformers used for this experiment are rated 120V-120V, 0.6kVA. There are three of them on each set of wall shelves. The set of windings connected to the source side of the transformer are called primary windings, and those connected to the load are named secondary windings. To achieve a 600 volt-ampere rating, these two sets

Transformer Model

of main primary and secondary windings must be in parallel. The other two windings are information (instrumentation) windings and are not designed to support a load.

Figure 1 defines the currents that are referred to throughout the experiment.

1. Figure 6 shows the connections for performing the open-circuit and short-circuit tests. Since the turns ratio is 1:1, both tests are done on the same side of the transformer. The open-circuit test is performed at rated voltage (120V), and the short-circuit test is performed at rated current (5 AMPS).

The only new instrumentation is the wattmeter. The meter has a number of terminals, but they are easily separated. Terminals on the left side of the front panel correspond to the current terminals, while terminals on the right side correspond to voltage. The current coil must be connected in series with the network for which you are taking power measurements. The voltage coil is connected between line and neutral of the network for single-phase measurements. The terminals marked common are connected internally. Using the function selector on the right side of the front panel, power, voltage, and current can all be measured.

Use the 200 V and the 20 V voltage range settings for the open circuit and short circuit test respectively. Both tests use the 5000 mA setting for the current range. Make sure the Full Scale (F.S) switch is set in **calibration** position.

OPEN CIRCUIT TEST

The secondary jumper must be disconnected for the open circuit-test, while applying rated voltage, 120 V, from the Single-Phase AC Source to the primary side of the transformer. Record Power, Current, and Voltage.

Power	Current	Voltage
		120V

Transformer Model

SHORT CIRCUIT TEST

The short-circuit test is run with the secondary jumper connected. **SLOWLY** increase (the **voltage is less than 20Vrms**) the Single-Phase AC Source from the zero setting until a 5 AMP reading is achieved on the meter. Allow a little time for the system to stabilize at 5 AMPS and then, record Power, Current, and Voltage.

Power	Current	Voltage
	5A	

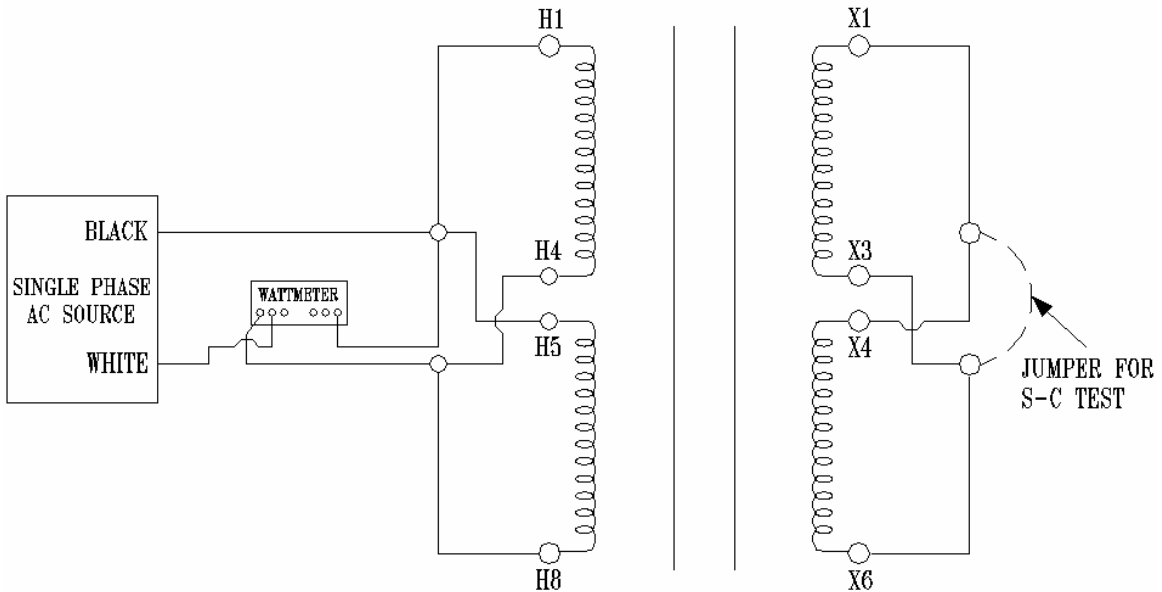

Figure 6

REPORT

Study questions

Explain the concept and procedure for open- and short-circuit testing of transformers.

Open-Circuit Test

This test allowed us to find..... (Continue expanding in your own words, say what you did and why you did it. Include all equations, table, data, plots, and results for this part)

Short-Circuit Test

This test allowed us to find (Continue expanding in your own words, say what you did and why you did it. Include all equations, table, data, plots, and results for this part)

Explain why the tests should be performed on the high or low voltage sides as appropriate.

Why we did it at the same side in our experiment?

Which electrical and magnetic characteristics of the transformer are the most important ones?

Why are these characteristics the most important?

Transformer Model

This is to be done **in class** before you leave the Lab.

Derive the equivalent circuit for the transformer tested during this experiment. Find **R_c , X_m , X_1 , X_2 , R_1 , R_2 , Z_{eq} , R_{eq} , X_{eq} , Q_{sc} , Q_{oc} , power rating, pf oc, and pf sc.**
Draw the equivalent circuit.