

EXPERIMENT Transmission Line

Transmission Lines

OBJECTIVE

This experiment demonstrates the steady-state performance characteristics of power transmission lines and some of the effects of control measures on transmission line performance.

REFERENCE

1. “Elements of Power System Analysis”, Fourth Edition, William D. Stevenson, Jr., McGraw-Hill Book Company, 1982, Chapter 5.

INTRODUCTION

Figure 1 shows the internal connects of the model transmission line. The jacks and switches on the hardware correspond to the jacks and switches on the figure. Switch S_1 is used to change the line configuration from three-phase to single-phase. Switch S_2 totally disconnects the excited transmission line from the load; this feature permits testing for line regulation. The 1Ω resistors in phase A permit current measurements with the oscilloscope.

The model transmission line is made from pi-sections and is approximately equivalent to a $15KV_{L-L}$ line of 19 miles length. 19 miles is a long run for a 15KV line, but it is very appropriate for the laboratory since it demonstrates all the principles well.

The laboratory set-up is made as shown in Figure 2. All meters are marked to indicate their function in the system. The oscilloscope is connected to read the input voltage on Channel 1 and input current on Channel 2, the output voltage on Channel 3 and output current on Channel 4. This permits measurement of input and output power factor angles and the angle between input and output voltages by merely using the delay function on the oscilloscope. **Note:** Use Probes for Channels 1 and 3.

One of the wattmeters on the output side is labeled Q_o . This meter is used to measure the A-phase current and the voltage difference between phases B and C. The reading from the meter is $\sqrt{3} Q_{phase}$.

Transmission lines

The induction motor connected to the dynamometer provides the load for the transmission line. The other machine connected to the line output is a synchronous condenser which is used to study the effects of power factor correction.

The set-up being used permits measurement of the following signals: input line-to-neutral voltage, input line current, input phase power, input power factor angle, output line-to-neutral voltage, output line current, output phase power, output power factor angle, output reactive power, efficiency, angle between input and output voltage, and voltage drop. Transmission line regulation can be demonstrated by using switch S_2 .

All measurements during this laboratory experiment are made for a 70V line-to-neutral output voltage. This is done because the classroom theory developments have all been based on a known constant output voltage. The measurements made during Parts 5, and 6 will indicate the problem of voltage control in a transmission system.

SUGGESTED PROCEDURE

1. Connect the system shown in Figure 2. Connect the system exactly as it is shown. Failure to do so may preclude measurement of some quantities. Use Figure 3 to connect the analog watt-meter (device Q_0 in Figure 2).

2. Remove the dynamometer lock. Start by smoothly increasing the output voltage from the 3 ϕ AC Source until the transmission line output voltage is $70V_{LN}$. Apply 0.5A dc to the field of the synchronous condenser. These actions energize the transmission line and start both machines. If the synchronous condenser does not start, just give the rotor a spin. This action has established the “base case”. Record all meter readings. Measure the input power factor angle by displaying the input voltage on channel 1 and the input current on channel 2. The output power factor angle is measured using channel 3 and channel 4. The angle between the input and output voltage is measured by comparing channel 1 and channel 3.

<u>I_{exc}</u>	V_{in} L-N	I_{in}	P_{in}	<P_{fin}	V_{out} L-N	I_{out}	P_{out}	<P_{fout}	Q_{out}	<V_{in}-V_{out}
0.5A					70V					

Base Case

Transmission lines

3. To find the voltage regulation turn switch S_2 to the off position and measure the output voltage. This one measurement is sufficient to demonstrate regulation. Turn switch S_2 back to the on position.

$$\text{Voltage Regulation: } VR = \frac{V_{nl} - V_{fl}}{V_{fl}} \times 100\%$$

	V_{IN}	V_{OUT}
Switch S2 on		70V
Switch S2 off		

4. Place 5 load bank switches up and apply field excitation to the dynamometer until the induction motor is **loaded to 0.8** Newton-meters of torque. Adjust the 3- ϕ AC Source for *70V line to neutral* transmission line output voltage. Repeat the measurements made in Part 2. Note particularly the changes in the power factors, voltage angle, and voltage drop.

<u>I_{exc}</u>	V_{in} L-N	I_{in}	P_{in}	$\angle P_{fin}$	V_{out} L-N	I_{out}	P_{out}	$\angle P_{fout}$	Q_{out}	$\angle V_{in} - V_{out}$
0.5A					70V					

Loaded 0.8 Newton-meters

Transmission lines

- Return the system to the base case. Fill out Table 7.1 by increasing field excitation of synchronous condenser from 0.5 ADC to 2.5 ADC. Keep output voltage constant (70 V) during the measurements.

<u>I_{exc}</u>	V_{in} L-N	I_{in}	P_{in}	<P_{fin}	V_{out} L-N	I_{out}	P_{out}	<P_{fout}	Q_{out}	<V_{in}-V_{out}
0.5A					70V					
1.0 A					70V					
1.5 A					70V					
2.0 A					70V					
2.5 A					70V					

Table 1 Base Case

- Repeat Parts 5, apply field excitation to the dynamometer until the induction motor is loaded to 0.8 Newton-meters and record your data in Table 7.2

<u>I_{exc}</u>	V_{in} L-N	I_{in}	P_{in}	<P_{fin}	V_{out} L-N	I_{out}	P_{out}	<P_{fout}	Q_{out}	<V_{in}-V_{out}
0.5A					70V					
1.0 A					70V					
1.5 A					70V					
2.0 A					70V					
2.5 A					70V					

Table 2 0.8N-M Load

Transmission lines

7. Fill out tables 3 and 4. The quantity X_L is the per-phase reactance, L is the per-phase inductance, and R is the per-phase resistance.

Base Case Calculations (part 2.)

S_{IN}		Q_{IN}		Q_{loss}	
S_{OUT}		Q_{OUT}		P_{loss}	
X_L		L		R	

Table 3

Loaded Line Calculations (part 4.)

S_{IN}		Q_{IN}		Q_{loss}	
S_{OUT}		Q_{OUT}		P_{loss}	
X_L		L		R	

Table 4

Have instructor sign off the calculations before you leave the lab.

Use these calculations to study for the quiz.

REPORT

1. Explain the differences between the measurements of Part 2 base case and Part 4 loaded case. Discuss the differences in:

- Voltage Drop Across TL
- Current flow through TL
- Real power drop in the transmission line Pin-Pout (losses in the TL)
- Input and output power factor angles
- Input and output Q's
- Imaginary power drop in the transmission line Qin-Qout

Remember voltages, currents, and impedances are complex.

2. Using data from Part 3, find voltage regulation of the transmission line. **Note:** use the base case value as the full load value.

$$\text{Voltage Regulation: } VR = \frac{V_{nl} - V_{fl}}{V_{fl}} \times 100\%$$

3. Describe the impact of load-side power factor correction on the operation of the transmission line. Relate your description to the measurements from Parts 5, and 6.

Describe impact of Load-side power factor correction on these quantities:

- Voltage Drop Across TL
- Current flow through TL
- Real power Pin, and Pout
- Real power drop in the transmission line Pin-Pout (losses in the TL)
- Input and output power factor angles
- Input and output Q's
- Imaginary power drop in the transmission line Qin-Qout

Remember voltages, currents, and impedances are complex

4. Explain how a wattmeter can be used to measure reactive power, as done in this experiment. Must show proof such as vector drawing of V, I remember that a wattmeter measures real power.

5. Determine the per-phase inductance and resistance of the model transmission line and explain how you found it. Show all work.

Transmission lines

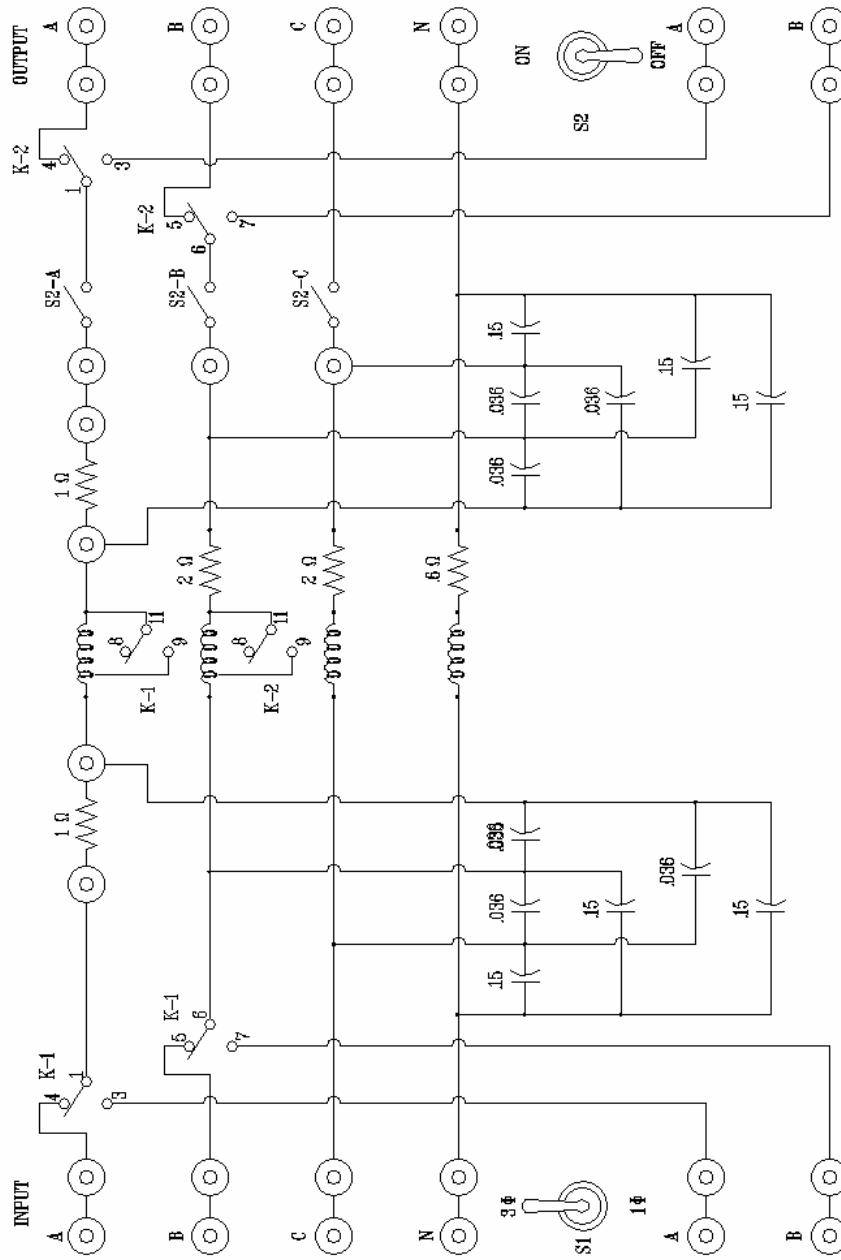

Figure 1: MODEL TRANSMISSION LINE

Transmission lines

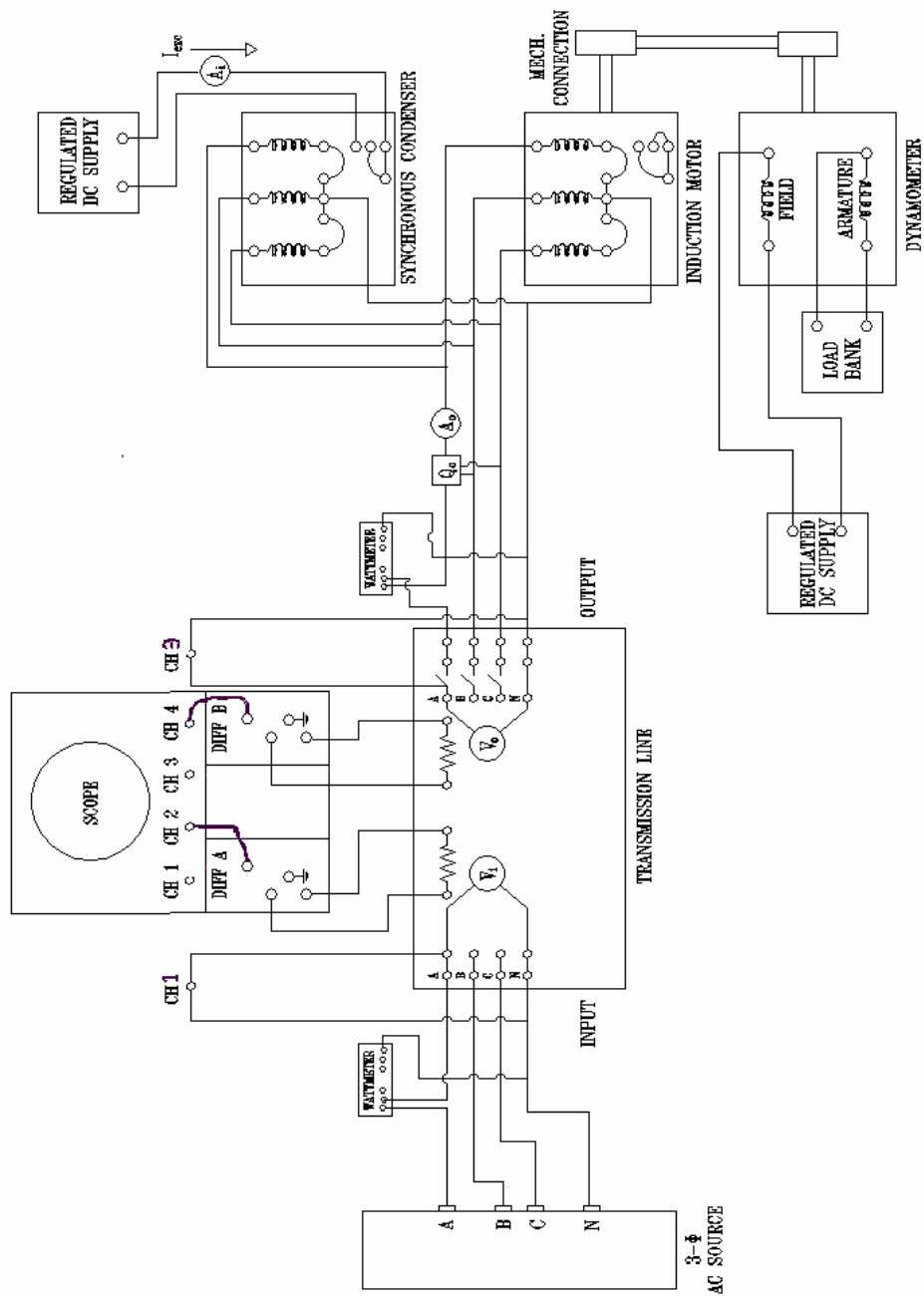

Figure 2: TEST CONNECTIONS

Transmission lines

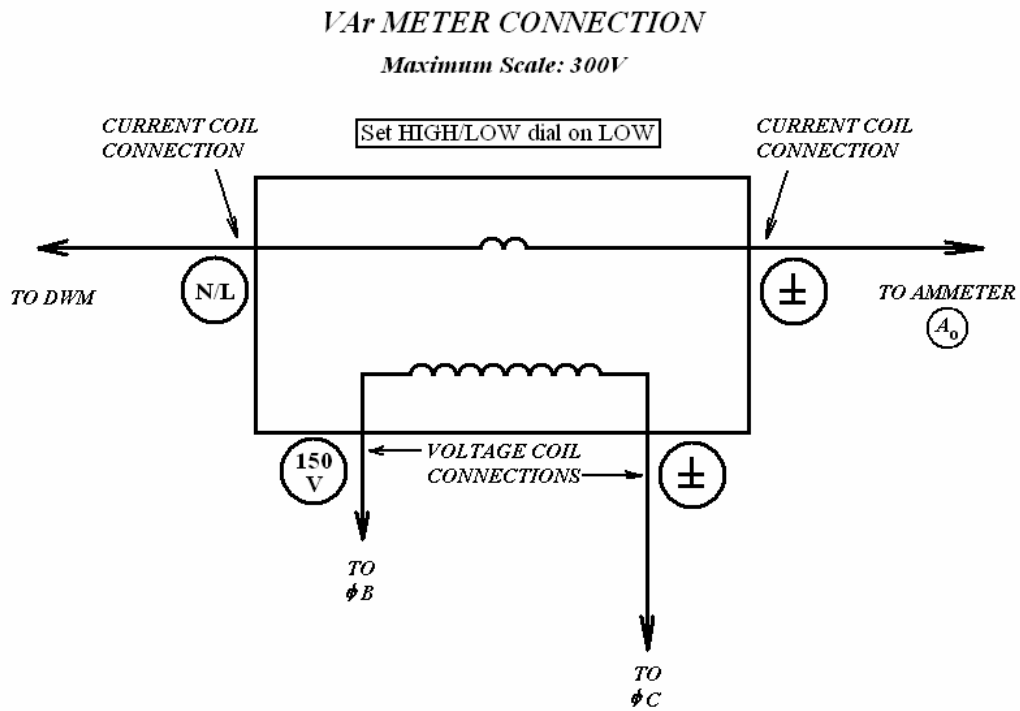
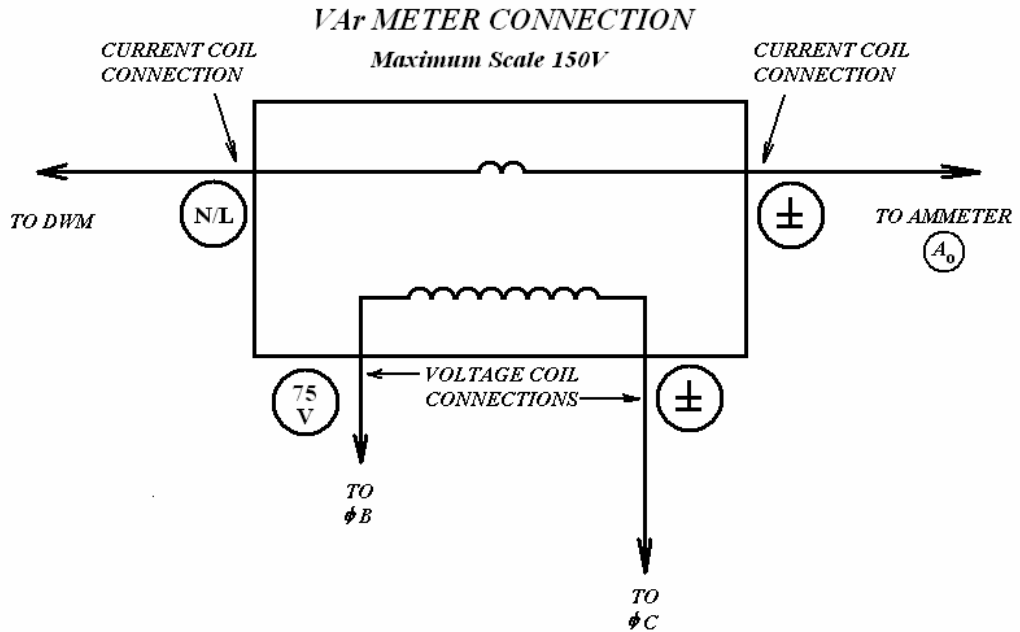

Figure 3: ANALOG WATT-METER CONNECTIONS