

EXPERIMENT Synchronous Machine

Synchronous Machines

OBJECTIVE

Three-phase synchronous machines account for a high percentage of this country's power generation. Understanding the machine's behavior and determining its equivalent network and performance characteristics are of prime importance to a power engineer. This experiment studies the characteristics of doubly-excited synchronous motors and generators. Specific tests are run to determine equivalent circuit parameters, torque, and power factor control. This lab shows that system design considerations must include frequency, speed, power factor, and voltage. Also illustrated are important machine design parameters including linear versus non-linear magnetic characteristics and efficiency.

REFERENCES

1. "Electric Machinery", Fitzgerald, Kingsley, and Umans, McGraw-Hill Book Company, 1983, Chapter 7.
2. "Electric Machines", Sarma, M. S., William C. Brown Publishers, 1985.
3. "Electromechanical Devices for Energy Conversion and Control Systems", Del Toro, Vincent, Prentice-Hall, Inc., 1968.
4. "Electric Machinery and Transformers", Kosow, Irving L., Prentice-Hall, Inc., 1972.
5. "Electromechanical Energy Conversion", Brown, David, Hamilton, E. P., MacMillan Publishing Company, 1984.

BACKGROUND INFORMATION

The three-phase synchronous machine, illustrated in Figure 1, is literally a DC machine turned inside-out. The armature, excited by alternating current, is wound in the stator of the machine, and the direct current field is wound on the rotor of the machine. Electrical power is

Synchronous Machines

transferred to the rotor through stator mounted brushes that make contact with rotor mounted slip rings. The rotating field that is necessary for continuous torque development is accomplished by the AC utility supply.

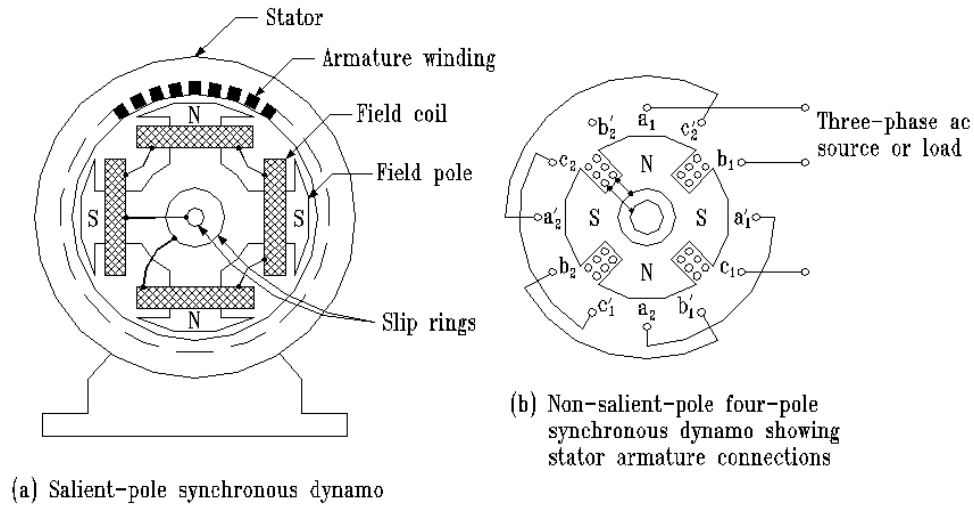
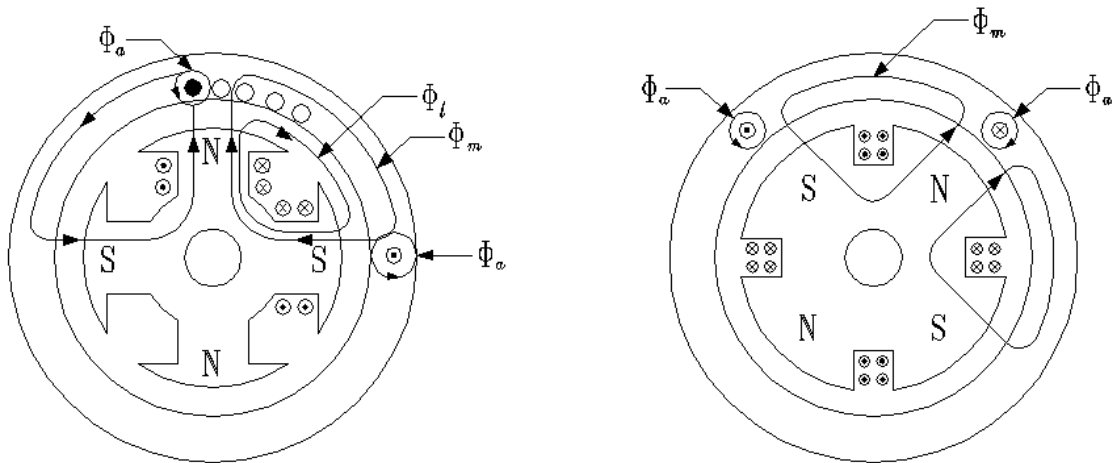

Figure 1: Cross-sections of synchronous machines.

As shown in Figure 1, the rotor can be of either the salient-pole type or the cylindrical (non-salient-pole) type. The machine used for this experiment is somewhat salient, but the impact of the salient is negligible. In either case, the flux of the field is fairly uniformly distributed throughout the stator, as shown in Figure 2.



(a) Salient-pole flux distribution

(b) Non-salient-pole flux distribution

Figure 2: Mutual and leakage fluxes of synchronous machines.

Figure 2 shows the assumed current direction for phase a of the stator winding. The flux produced by the stator (armature) current combines with the flux produced by the rotor (field) circuit to create the mutual flux. Any flux produced that does not link another winding in the machine is called leakage flux.

We shall now explore how torque is produced in the cylindrical rotor synchronous machine. We first assume that a direct current has been applied to the field circuit. Thus, the rotor contains alternate North and South magnetic poles. The next step is to apply a symmetrical three-phase current to the armature winding. Such a current waveform is shown in Figure 3. If the armature windings are properly distributed, each phase of the input current produces a sinusoidal distributed MMF, or magnetic field, centered on each winding axis. The three MMF distributions are:

Synchronous Machines

$$F_a = F_{\max} \cos \omega t \cos \theta \quad \text{A - T} \quad \text{Eq. 1}$$

$$F_b = F_{\max} \cos(\omega t - 120^\circ) \cos(\theta - 120^\circ) \quad \text{A - T} \quad \text{Eq. 2}$$

$$F_c = F_{\max} \cos(\omega t + 120^\circ) \cos(\theta + 120^\circ) \quad \text{A - T} \quad \text{Eq. 3}$$

and

$$F_{\max} = I_{\max} k_w N_{\text{phase}} \quad \text{A - T} \quad \text{Eq. 4}$$

where

$$F_{\max} = \text{peak MMF}$$

$$I_{\max} = \text{peak current}$$

$$k_w = \text{winding factor}$$

$$N_{\text{phase}} = \text{series connected turns per phase}$$

$$k_w N_{\text{phase}} = \text{effective turns}$$

The total MMF due to the armature currents is the sum of the individual MMF's. Thus,

$$F_{\text{total}} = F_a + F_b + F_c \quad \text{A - T} \quad \text{Eq. 5}$$

After some trigonometric and algebraic manipulation,

$$F_{\text{total}} = \frac{3}{2} F_{\max} \cos(\omega t - \theta) \quad \text{A - T} \quad \text{Eq. 6}$$

Eq. 6 describes a traveling wave which moves around the stator at a velocity

As long as the applied frequency is constant, Eq. 7 tells us that the speed of a synchronous motor will be constant. Therefore, the only way to change the speed of a synchronous motor is to change the applied frequency. However, if the frequency is decreased

Synchronous Machines

to slow the motor and the field current is held constant, the back EMF and the synchronous impedance also decrease. Thus, if the applied voltage V_t is held constant, the armature current will increase until it burns the armature windings. Therefore, to control the speed of a synchronous motor, the terminal voltage must be adjusted roughly proportionally to the frequency.

$$N_{sync} = \frac{120f}{P} \text{ RPM} \quad \text{Eq. 7}$$

where N_{sync} = synchronous speed
 f = applied frequency, Hz
 P = number of magnetic poles in machine

Figure 3 and 4 illustrate the concept of the rotating MMF.

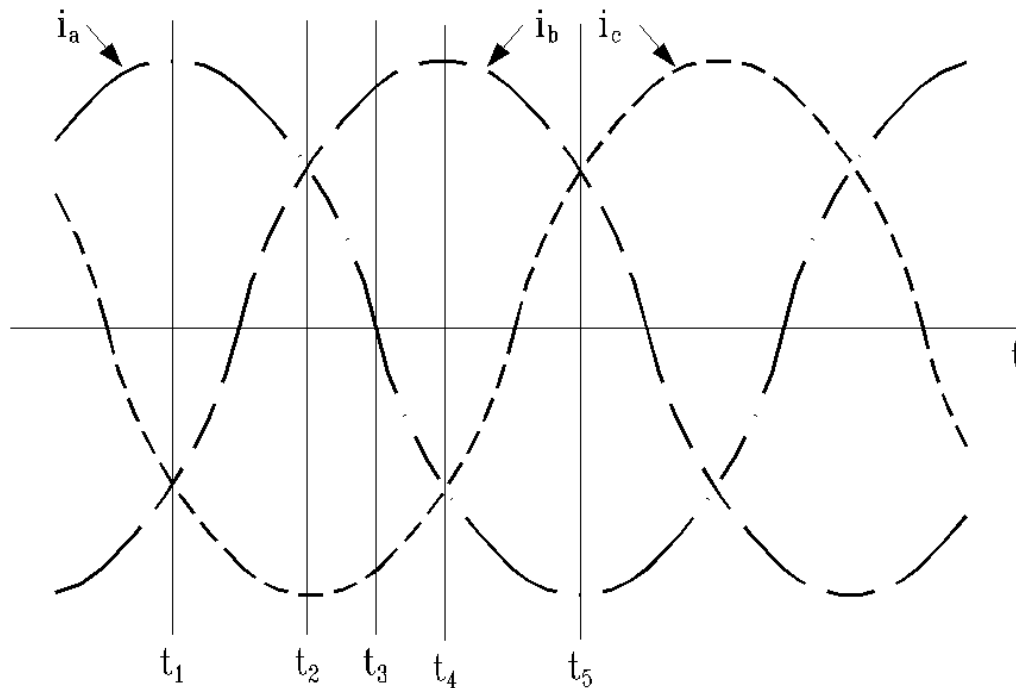

Figure 3: Balanced three-phase alternating currents showing time increments.

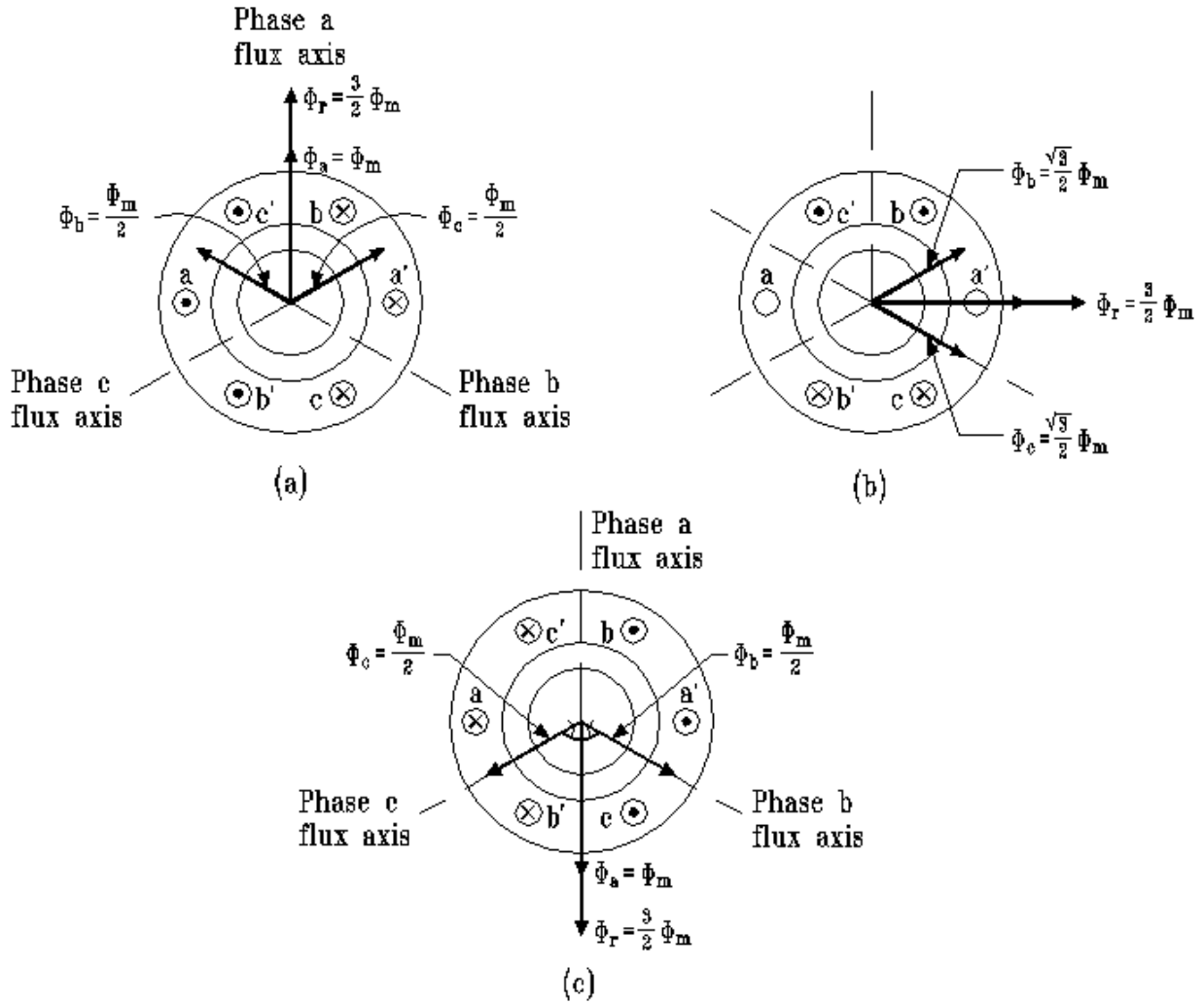

Figure 4: Representation of the rotating magnetic field for three time increments from Figure 3.

Having previously established the rotor magnetic field and having now established the stator magnetic field, the machine will attempt to align the two fields. This attempt at alignment produces torque at the rotor shaft. However, since the stator field is rotating at synchronous speed, the rotor is dragged right along with the stator field, thus producing a continuous torque.

The two fields can only completely align themselves if there is no load torque attempting to turn the rotor in the opposite direction. If a load torque exists, the fields must separate enough to produce the required torque. The concept is described by Eq. 8 and illustrated by Figure 4.

Synchronous Machines

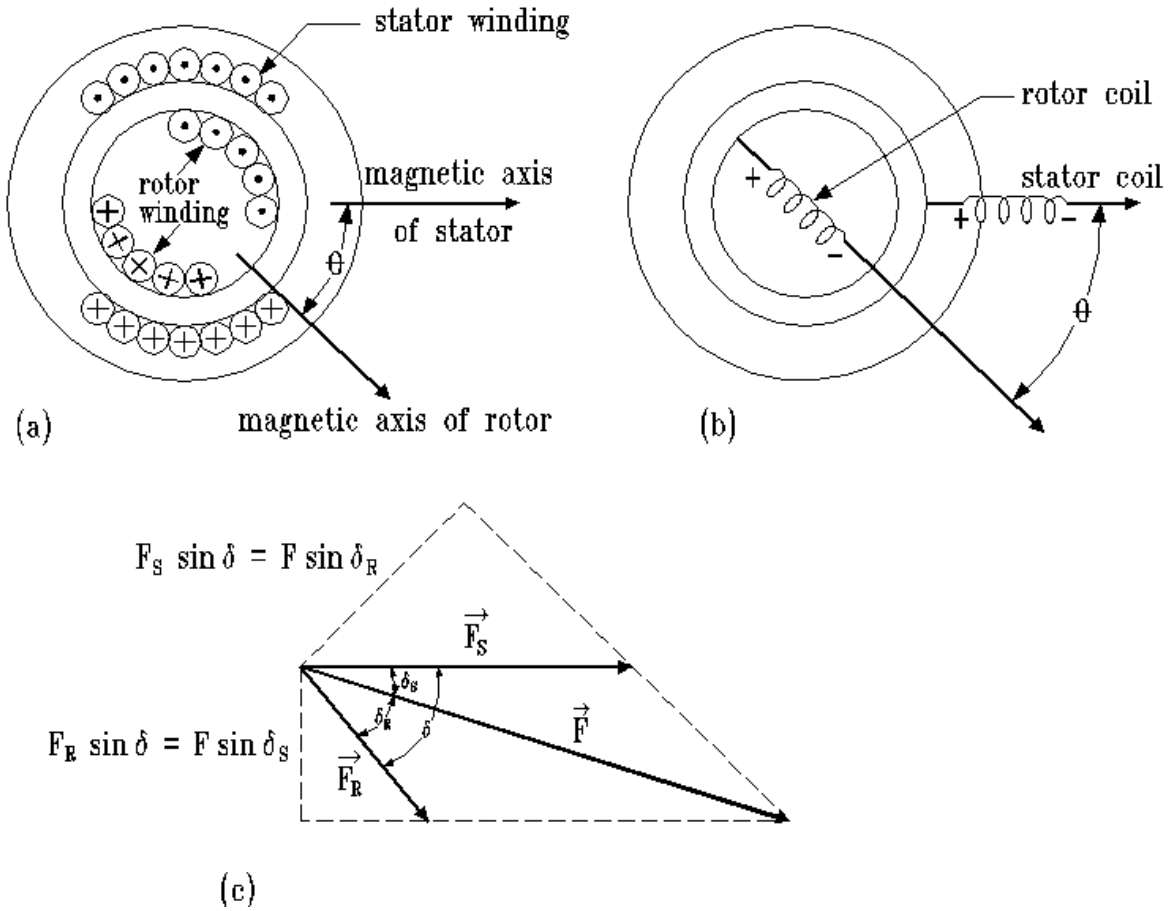

Figure 5: An elementary cylindrical rotor synchronous machine.

From Reference 1, the torque produced by the cylindrical rotor machine is

$$T_{dev} = -\frac{P u_o \pi D \ell}{2g} F_s F_R \sin \delta \quad \text{Eq. 8}$$

- where
- T_{dev} = developed torque
 - P = number of poles
 - D = rotor diameter
 - ℓ = length of rotor (axial)
 - g = length of gap

Synchronous Machines

Eq. 8 indicates that the torque is proportional to the peak values of the stator and rotor MMF's and the sine of the electrical space angle between them. The negative sign indicates that the fields are attempting to align themselves. Of course, an equal and opposite torque is established within the stator.

If the machine is being used as a generator, torque is being supplied by a prime-mover. The generator load current produces a rotating magnetic field in the stator (armature) which tries to oppose the rotation of the rotor. This action produces a torque which is transmitted to the generator foundation. Figure 6 shows the torque versus torque angle δ characteristic in both the motor and generator modes.

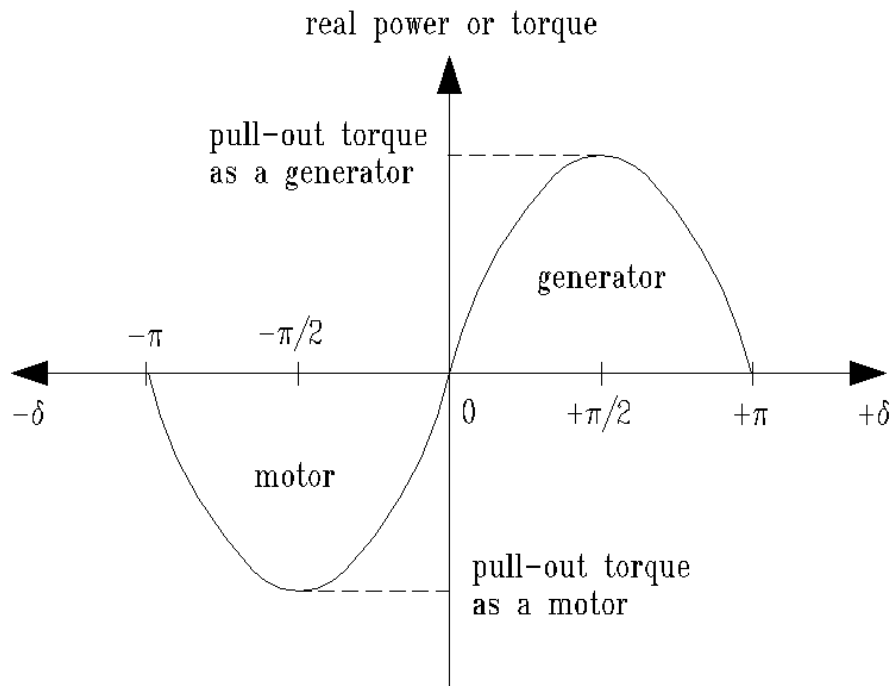

Figure 6: Steady-state torque-angle characteristic of a cylindrical rotor synchronous machine.

As the rotor moves within the stator, the field induces voltage in the armature winding of the machine. This voltage is called the generated voltage in a generator and the back EMF in a motor. Its magnitude is directly proportional to the speed of the rotor, the strength of the field, and the effective turns of the armature. If the field poles are properly shaped and the armature

Synchronous Machines

winding properly distributed, the induced voltage is sinusoidal. Figures 7 and 8 illustrate the phenomenon.

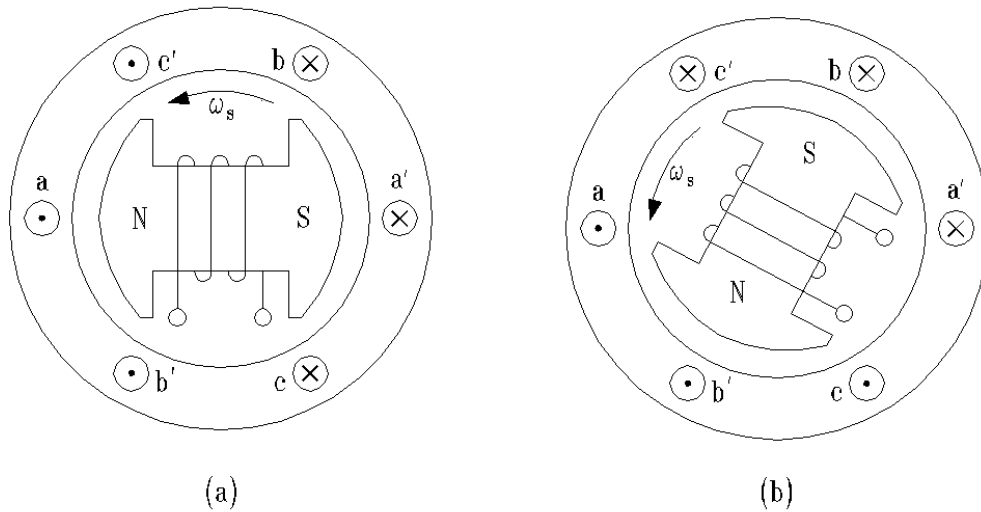

Figure 7: Induced voltages at two different times in the armature of a synchronous machine.

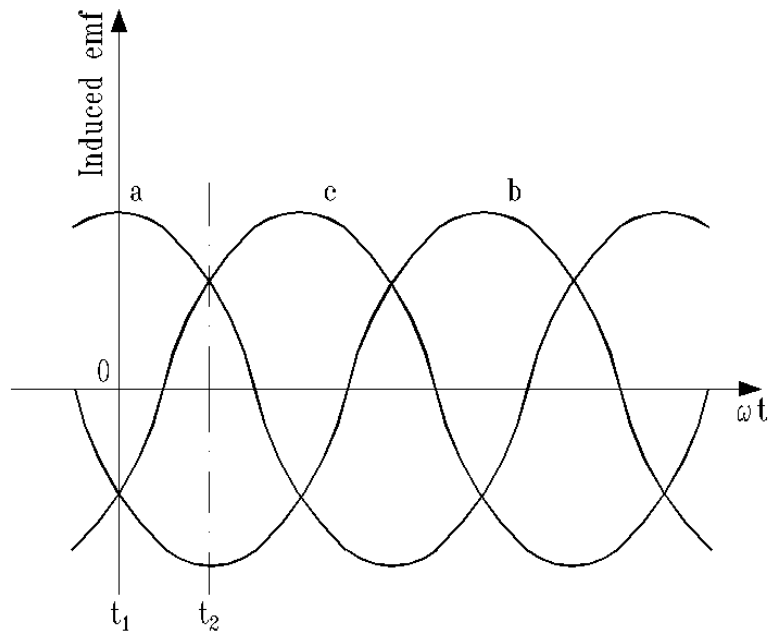

Figure 8: Time history of three-phase induced voltages for generator of Figure 7.

Synchronous Machines

If the machine is supporting a load (armature current not equal to zero), then there is a rotating magnetic field created by the armature. The armature field tends to reduce the net flux in the machine air gap, which in turn causes a reduced voltage. This process is called armature reaction.

We now have enough information to develop equivalent circuit models for the synchronous machine. The models are shown in Figure 9 and 10 where

E_f = no-load generated voltage

E_r = generated voltage including armature reaction

I_a = armature current

X_ϕ = inductance to account for armature reaction

X_ℓ = armature leakage inductance

X_s = synchronous reactance

R_a = per-phase armature resistance

V_t = per-phase terminal voltage

Synchronous Machines

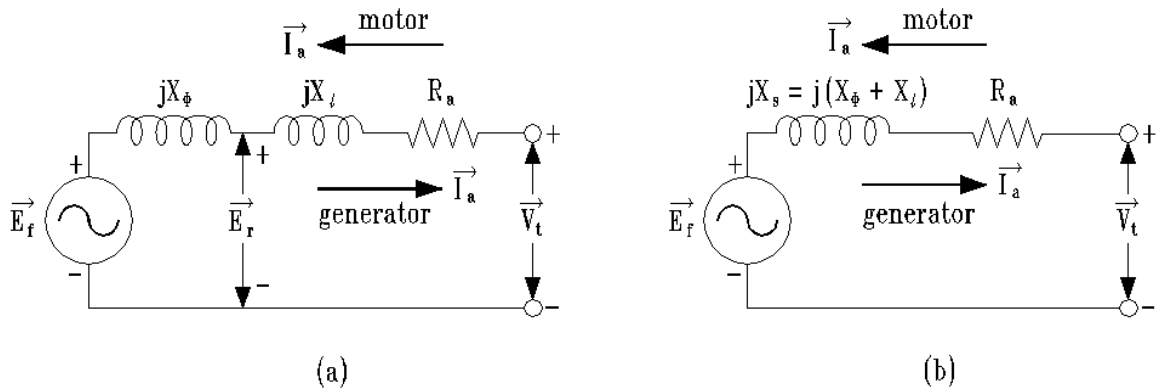

Figure 9: Per-phase equivalent circuits of a cylindrical-rotor synchronous machine.

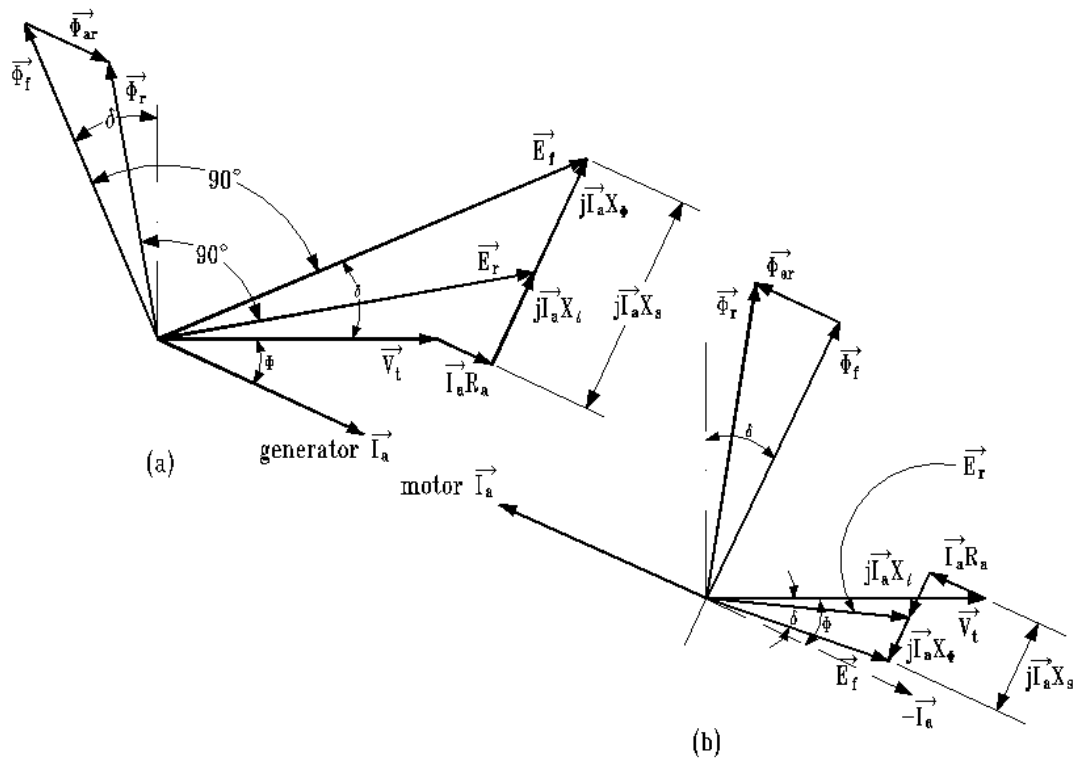

Figure 10: Phasor diagrams for a cylindrical-rotor synchronous machine, for the case of a lagging power factor (armature current lagging behind the terminal voltage). a) Generator, b) Motor.

Synchronous Machines

The generator shown in Figure 10 is overexcited ($E_f > V_t$), indicating that the field is producing more magnetic energy than the machine needs for the required output real power. The excess reactive energy is used to charge the inductances of the external system. The motor shown in Figure 10 is under excited ($E_f < V_t$) indicating that the external system must provide reactive energy to the motor to supplement the weak strength of the field. The magnitude of the armature current reflects the transfer of reactive energy into or out of the machine. If the field is providing just the right amount of flux to produce the torque, the armature current will transmit only real power. At this condition, the armature current magnitude is minimized for this particular load and the terminal power factor is unity. Figure 11 shows the armature current versus field current curves for different real power conditions. These are called the V-curves.

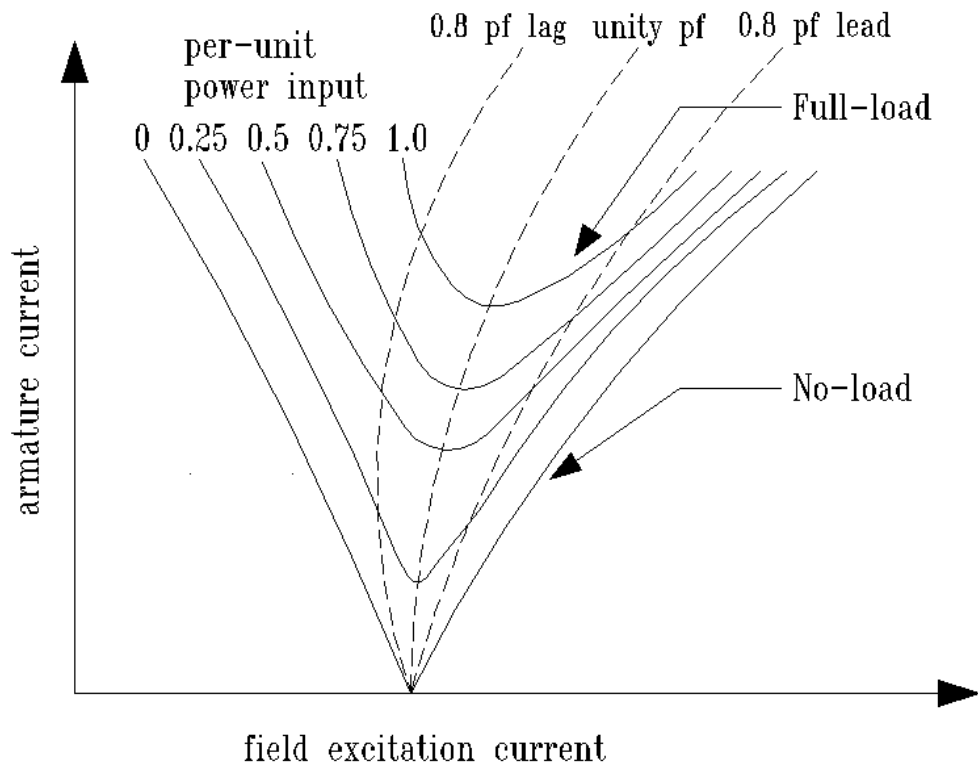

Figure 11: Synchronous motor V-curves.

Synchronous Machines

For a given level of real power transmission, the position on the V-curve is controlled by the magnitude of the field current. In fact, at very low power levels the synchronous motor can be made to “look” capacitive and can be used as a continually adjustable power factor corrector.

The impedance parameters for the equivalent circuits can be found by testing the machine. The armature resistance is found by placing a DC source across the appropriate armature terminals and measuring the voltage and current. The resistance is the ratio of voltage to current multiplied by an appropriate correction to account for skin effect (approximately 1.2 at 60 Hz).

The total impedance of the equivalent circuit is found from the ratio of no-load terminal voltage to short-circuit current at a specified field current. Figure 12 shows the open-circuit voltage curve (OCC) and the short-circuit current curve (SCC) for a typical machine. The voltage curve slope begins to decrease as the field current increases due to saturation of the iron in the machine.

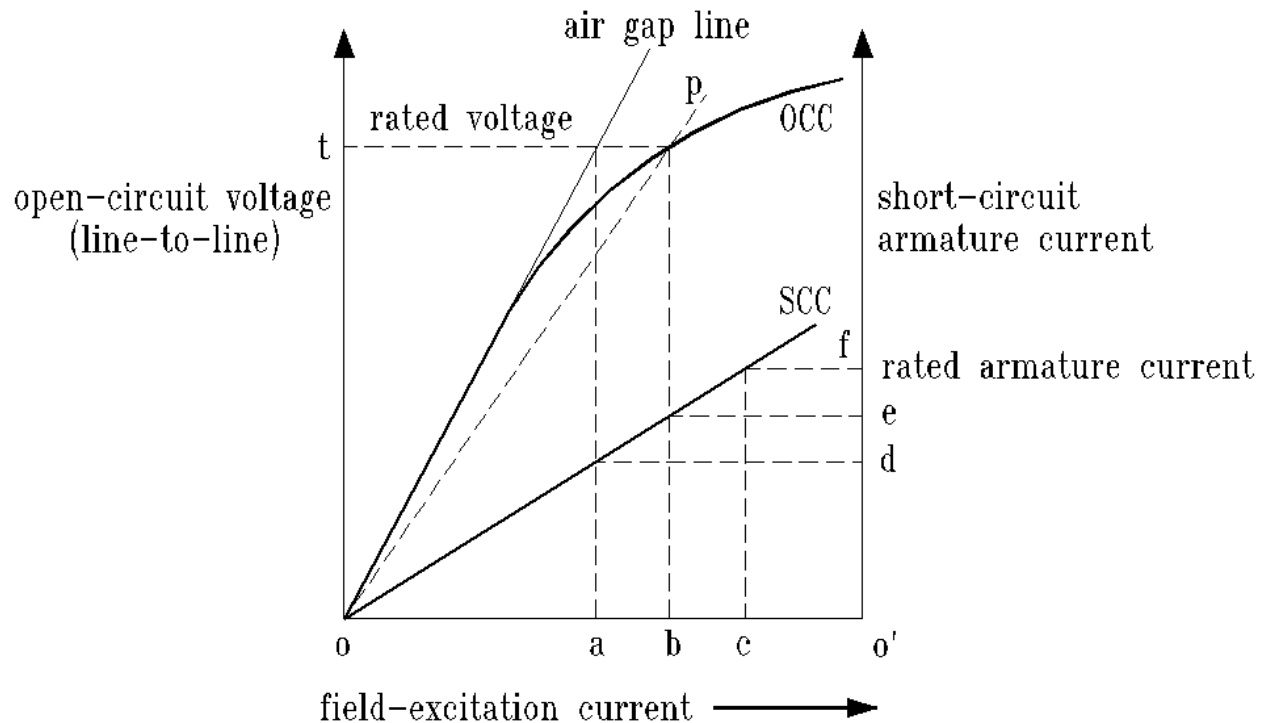

Figure 12: Open-circuit and short-circuit characteristics of a synchronous machine at rated speed.

Synchronous Machines

The impedance is

$$Z = R_1 + jX_s \quad \Omega/\text{phase} \quad \text{Eq. 9}$$

The magnitude of this impedance is found from Figure 12.

$$|z| = \frac{O-C \text{ Rated } TERMINAL \text{ Voltage}}{S-C \text{ armature current at same } I_f} = \frac{O't}{O'e} \quad \text{Eq. 10}$$

Since the magnitudes of the impedance and R_a are both known, the synchronous reactance can be easily found.

THE TEST SET-UP

The machines used for this experiment are four-poles, three-phase, wound-rotor induction motors, but they work quite well as doubly-excited synchronous machines. The stators are rated for 120V line-to-line and are wye-connected which is 69.3V line-to-neutral. Both the stator and the rotor windings are rated for 1.5 amperes, but they will handle 2.5 amperes for short periods of time. The motor being tested operates at same the speed of dynamometer.

The motor is started as an induction machine by short-circuiting the rotor windings. After acceleration, the short-circuit is removed and DC current is applied to the rotor field. The DC field causes the motor to “jump” into synchronism, where it remains until it becomes overloaded.

SUGGESTED PROCEDURE

1. Connect the circuitry shown in Fig. 13. This set-up is used to test the synchronous machine as a motor.

Remove lock from dynamometer. Place the DPDT switch in position 1 to convert the rotor to an induction rotor. Increase the 3- ϕ AC SOURCE output to $120V_{L-L}$. Now, place the switch in position 2 and apply 0.5 Adc to the rotor. This action brings the machine into synchronism. Use the digital tachometer to verify synchronous speed.

During the next procedures, observe the field current magnitude, armature current magnitude and phase, and the instantaneous line-to-neutral terminal voltage. The angle between the phase voltage and phase current is the “power factor” angle. The motor terminal voltage must be maintained at $120V_{L-L}$ throughout these tests.

Set four load switches up with the field current still at 0.5 ADC. Slowly increase the dynamometer field current (load switches “up”) watch the dynamometer torque readout until the synchronous motor stalls (loses synchronism). Note the value of I_{arm} and Torque, reset to just below these values get a maximum stable values for the table below at each value of I_{field} . Complete Table 1 for the given field current values. Note the impact of the field current on the torque capacity of the motor.

I_{field}	I_{arm}	Vphase to Iphase Delay from scope	Phase angle Calculated	V_{tL-L}	PF Calculated	Stall Torque
0.5A				120		
1.0A				120		
1.5A				120		
2.0A				120		

Table 1

Synchronous Machines

V-curves

Maintain the source voltage at $120V_{L-L}$ for the various dynamometer settings (no load, half load, and full load) vary the DC field current from 0.5 ADC to 2.0 ADC. Set four load switches up with the field current at 0.5 ADC. Slowly increase the dynamometer field current (4 load switches “up”) until the synchronous motor stalls (loses synchronism). Note the value of I_{arm} and Torque, reset to just below these values get a maximum value before it stalls. Do not change the dynamometer field settings for the rest of this part. For the table below at each value of motor field current **If** settings, only change the load switches from full, to $\frac{1}{2}$, and no-load. For each setting, record the armature current in Table 2. These data points are required to plot the V-curves of the motor.

If	Armature Current		
	No-Load no switches	$\frac{1}{2}$ Load 2 switches	Full Load 4 switches
0.50A			
0.75A			
1.00A			
1.25A			
1.50A			
1.75A			
2.00A			

Table 2

2. Open Circuit Characteristic

Reconnect the system as shown in Figure 14. Increase the dynamometer voltage until the generator is running at 1800 RPM. Keep the speed constant for these tests. With the generator unloaded, measure and record the RMS line-to-neutral phase voltage as the field current is slowly increased. Increase the field current until the terminal voltage is 1.1 p.u. (76.25 V). For several points, record the field current and the terminal voltage in Table 3. This data is used to plot the open-circuit characteristic (OCC). Return the field current to zero.

Synchronous Machines

I_{field}	V_{arm}	RPM
0.0A		1800
0.5A		1800
1.0A		1800
1.5A		1800
	76.2V	1800

Table 3 Open Circuit Characteristic

Short Circuit Characteristic

Connect the system as shown in Figure 15. Increase the dynamometer voltage until the generator is running at 1800 RPM. Slowly increase the field current until the phase current is 1.3 p.u. (1.95 A). Measure and record the RMS phase current and the field current in Table 4 for several points. This data is used to plot the short-circuit characteristic.

I_{field}	I_{phase}	RPM
	0.5A	1800
	1.0A	1800
	1.5A	1800
	1.95A	1800

Table 4 Short Circuit Characteristic

Finding Armature Resistance

Connect one of the synchronous machine armature phases to the regulated DC supply. Increase the source current to 0.5 amperes. Record the voltage and current. This ratio of voltage to current is used to find the armature resistance. Remember this is a DC resistance measurement, but we need an AC resistance so include the skin effect of 1.2 in your calculations of $1.2(R_{dc}) = R_{ac}$.

I_{arm}	V_{arm}	DC arm resistance Calculated	AC arm resistance Calculated
0.5A			

Table 5 DC armature resistance

REPORT

(Short answers, be brief and <5 lines)

Experiment Introduction and Objective

(Less than 5 lines. Refer to the lab manual and **Re-Write** in your own words in bullets or numbering format).

<i>Part I – Synchronous Motor and Power Factor Correction</i>

Starting of a Synchronous Machine (motor)

Describe how to start the synchronous motor in our experiment.

What is the major function of the DPDT switch used in our experiment?

What is the synchronous speed of the motor?

How many poles does it have?

Power Factor

What did you observe in this part? Include any table, data and plots.

What does the *Stall* mean to a synchronous machine?

How is the phase angle and power factor calculated from the data collected?

Describe the capability of a synchronous motor to control the power factor seen by the supplying power system. See Table 1. (Short answers, be brief and <5 lines)

(Refer to the textbook pp 240-243 and the experiment results, answer it in your own words)

Torque production.

Explain the impact of field excitation (I_f) on torque production. Relate it to the fundamentals. See table 1.

(Examine equations listed on page 4-8 in the lab manual to figure out the answer. For more information about these equations, please refer to the Reference Book -1 listed in the lab manual. MMF is the abbreviation of MagnetoMotive Force)

V-Curves

What did you observe in this part? Include any **table, data and plots**.

Draw the motor V-curves from the data captured, and explain the system aspects of the characteristic described by the curves. See Figure 11 and Table 2.

(refer to textbook pp 235-240 to organize your explanation. We did not get a whole V-curve in our experiment, you need to give a general idea about the effect of field current on a synchronous motor with different amounts of load applied)

<i>Part II – Synchronous Generator</i>
--

Open-Circuit test Experiment

Explain what this part was for. Include Open-circuit Characteristic plot (E_a vs. I_f). Comment on this plot.

Short-Circuit test Terminals Experiment

Explain what this part was for. Include the Short-circuit Characteristic plot (I_a vs. I_f). Comment on this plot.

Armature Resistance- R_a

State why you measured this. And what is the Skin effect?

How will it influence the AC resistance comparing to the DC resistance?

Draw the Open-circuit and Short-circuit characteristic. Derive and draw the per-phase equivalent of the synchronous machine. See Figures 9b and 12, also Tables 3, 4, and 5.

(Pay attention to the Skin effect, and how to find the AC resistance from the DC resistance calculated)

Place derivations and schematic here, not just your answers.

Synchronous Machines

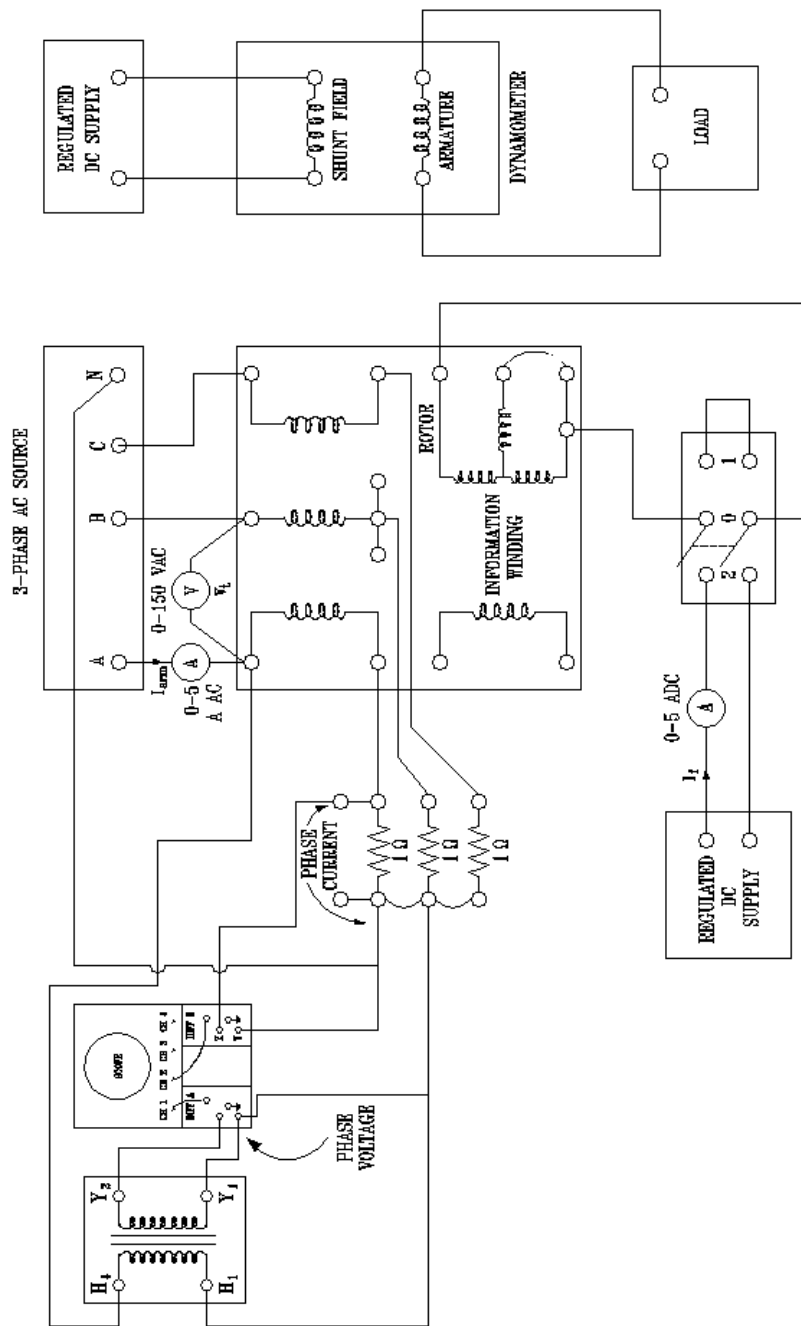

FIGURE 13: SYNCHRONOUS MOTOR

Synchronous Machines

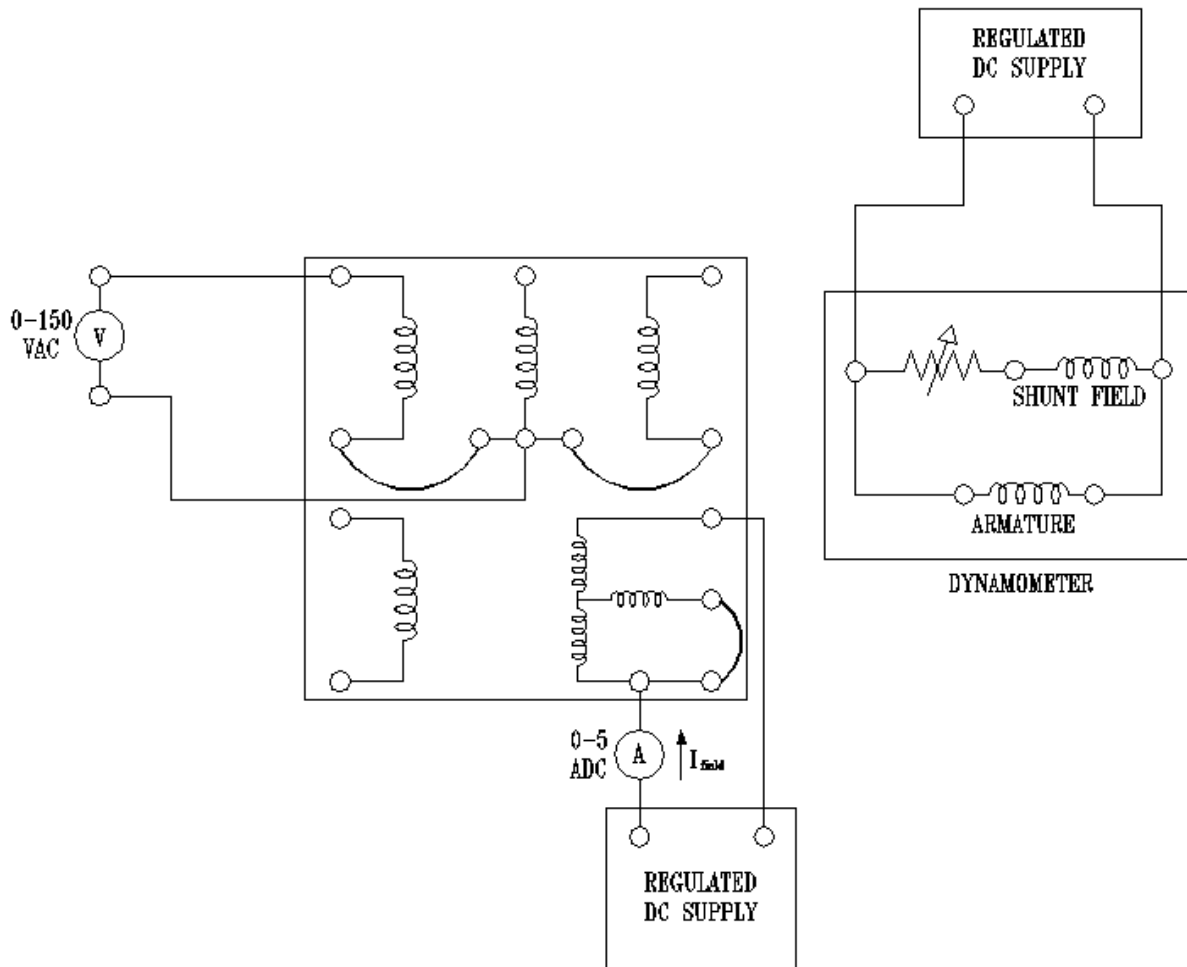

FIGURE 14: SYNCHRONOUS GENERATOR OPEN-CIRCUIT CHARACTERISTIC

Synchronous Machines

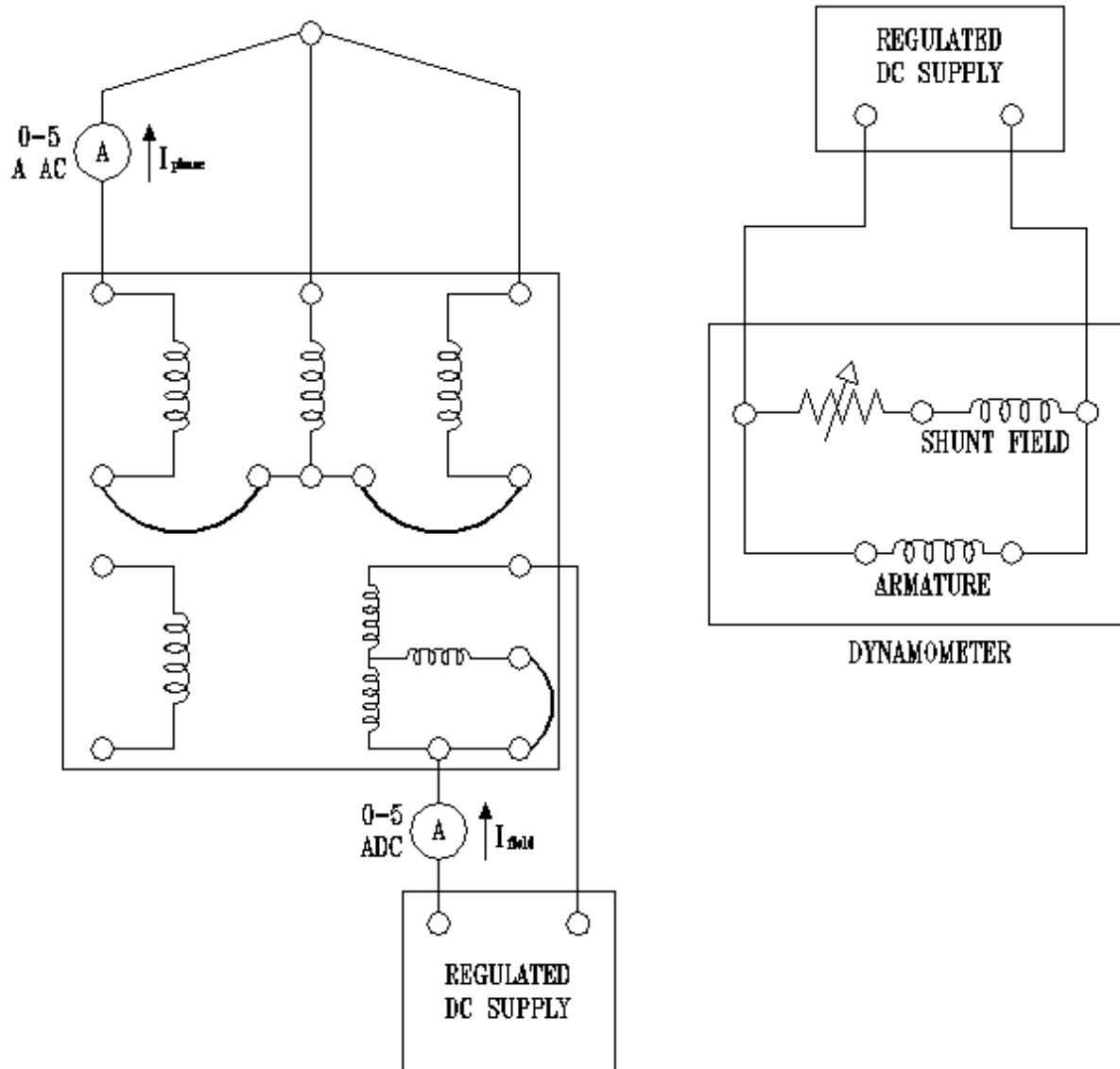

FIGURE 15: SYNCHRONOUS GENERATOR SHORT-CIRCUIT CHARACTERISTIC