

EXPERIMENT *Electronic Ballast*

Electronic Ballast for Fluorescent Lamps

OBJECTIVE

The objective of this experiment is to understand the role of ballast in fluorescent lighting systems and the advantages of fluorescent lamps driven by electronic ballast over the conventional incandescent lamps.

REFERENCES

- [1] J. Waymouth, *Electric Discharge Lamps*. Cambridge, Mass.: The M.I.T. Press, 1971.
- [2] P. C. Sorcar, *Energy Saving Lighting Systems*. New York, NY: Van Nostrand Reinhold Company Inc. 1982.
- [3] A. E. Emanuel and L. Peretto, "The response of fluorescent lamp with magnetic ballast to voltage distortion," IEEE Transaction on Power Delivery, Vol. 12, No. 1, Jan. 1997, pp. 289-295.
- [4] Kazimierczuk, M.K. and Szaraniec, W., "Electronic ballast for fluorescent lamps," IEEE Transactions on Power Electronics, Volume: 8, Issue: 4, Oct. 1993 pp. 386-395.
- [5] R. W. Erickson, *Fundamentals of Power Electronics*. New York, NY: Chapman & Hall, 1997.
- [6] International Rectifier, "IRPLCFL2 42 Watt Compact Fluorescent Ballast Reference Design," <http://www.irf.com/technical-info/refdesigns/cfl-2.pdf>.

BACKGROUND INFORMATION

Light is defined as visually evaluated radiant energy, which stimulates man's eyes and enables him to see. Man has always sought to counter the influence of the darkness by

Electronic Ballast

creating artificial light. The discovery of electric power and the possibility of transmitting it in a simple manner facilitated the development of modern lamps. Today there are nearly 6,000 different lamps being manufactured, most of which can be placed in the following six categories: incandescent, fluorescent, mercury vapor, metal halide, high-pressure sodium (HPS) and low-pressure sodium (LPS). Except for incandescent lamps, all of these light sources can be termed as gas discharge lamps. Fluorescent and LPS lamps operate on low-pressure gaseous discharge, and the mercury vapor, metal halide and HPS lamps operate on high-pressure gaseous discharge. The mercury vapor, metal halide and HPS types are commonly known as high-intensity discharge (HID) lamps.

The major characteristics to be considered when choosing a lamp are its luminous efficacy, life, lumen depreciation and color rendering. Luminous efficacy is the measure of the lamp's ability to convert input electric power, in watts, into output luminous flux, in lumens, and is measured in lumens per watt (lm/w). The luminous flux of a light source is the electromagnetic radiation within the visible part of the electromagnetic spectrum multiplied by the sensitivity of man's eyes to that part of the light from the source. The visible portion of the spectrum covers the wavelength range from approximately 380 nm to 780 nm (Figure 1). The life of a lamp is the number of hours it takes for approximately 50% of a large group of lamps of the same kind to fail. Failure means that the lamp will no longer light or that light output has dropped to a specific percentage value. Lumen depreciation during life is a characteristic of all lamps. This is a process of lamp aging, an important consideration in lighting design. Finally, there is the matter of color rendering. The lamp types do not provide the same nominal "white." Their difference in spectral distribution can produce two effects within a lighted space. Some of the colors of objects within that space can appear unnatural or faded – reds can appear brown, violets nearly black, etc. Second, the entire space may "feel" warm or cool. For example, a mercury lamp, lacking in reds and oranges, makes a space seem cool, whereas an incandescent lamp, with deficiencies in the blue and violets, makes a space feel warm.

Incandescent lamps and gas discharge lamps generate light through two different physical mechanisms of electrical energy conversion. Incandescent lamps use the Joule-heating process by electrically heating high-resistance tungsten filaments to intense brightness.

Electronic Ballast

The electric behavior is simple. The lamp current is determined by the applied voltage and by the resistance of the tungsten filament. It is close to the v - i characteristic of a linear resistor. The spectrum of energy radiated from incandescent lamps is continuous with good color rendering. However, only about 10% of the electricity flowing through incandescent lamps is converted to light, as shown in Figure 2(a), and thus the luminous efficacy of incandescent lamps is low. Electric gas discharge lamps convert electrical energy into light by transforming electrical energy into the kinetic energy of moving electrons, which in turn becomes radiation as a result of some kind of collision process. The primary process is collision excitation of atoms in a gas to states from which they relax back to the lowest-energy atomic levels by means of the emission of electromagnetic radiation. The emitted electromagnetic radiation is not continuous, instead consisting of a number of more or less separate spectral lines. By modifying the composition of the gas used, the luminous efficacy can be varied considerably.

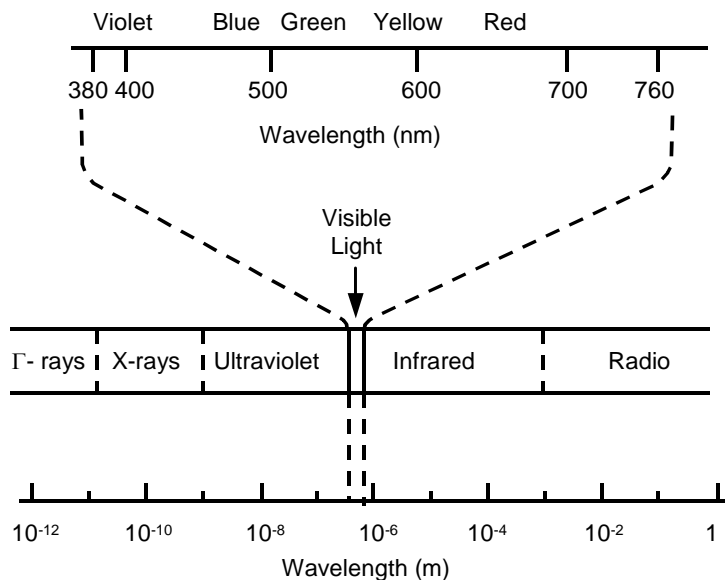

Figure 1. The electro-magnetic spectrum

Compared with incandescent lamps, gas discharge lamps have three great virtues as light sources: They are efficient energy converters, transforming as much as 20% to 30% of the electrical energy input into light energy output, as shown in Figure 2(b); they last a long time, 18 times longer than incandescent lamps if fluorescent lamps are taken as an

Electronic Ballast

example (rated life up to 20,000 hours); and they have excellent lumen depreciation, typically delivering 60% to 80% of the initial level of light at the end of life.

Although gas discharge lamps have tremendous advantages over incandescent lamps, they require an auxiliary apparatus called a ballast to run with them because gas discharge lamps have negative incremental impedance. Figure 3(a) shows a typical curve of discharge potential drop versus current when a lamp is operated from a DC power source. The curve can also be regarded as the locus of points (i, v) for which the time rate of change of electron density, dn_e/dt , is zero. For points above and to the right, dn_e/dt is greater than zero (production exceeds loss), and electron density would increase with time. For points below and to the left, dn_e/dt is less than zero, and electron density would decrease with time. Obviously, the slope of the curve, defined as incremental impedance $r \equiv dv/di$, is negative. The negative increase impedance characteristic poses a circuit problem for operating lamps. In general, a starting voltage V_s that is higher than the steady-state operation voltage is needed to establish ionization in the gas. After the discharge begins, the operating point (i, v) of the discharge would lie somewhere on the line of the constant $V = V_s$, which is in the domain for which the ionization rate exceeds the loss rate, and thus electron density n_e increases continuously with time. Consequently, the discharge current increases without any regulation, and eventually causes system failure.

As a result, gas discharge lamps cannot be directly connected to a voltage source. Certain impedance must be placed between the discharge lamp and the voltage source as a means to limit lamp current. For example, Figure 3(b) shows the effect of series resistance in stabilizing lamp current. The dotted lines V_{La} and V_R show the voltage potential across the discharge and resistor, respectively, and the solid line V_{AB} shows the potential across the pair in series.

Electronic Ballast

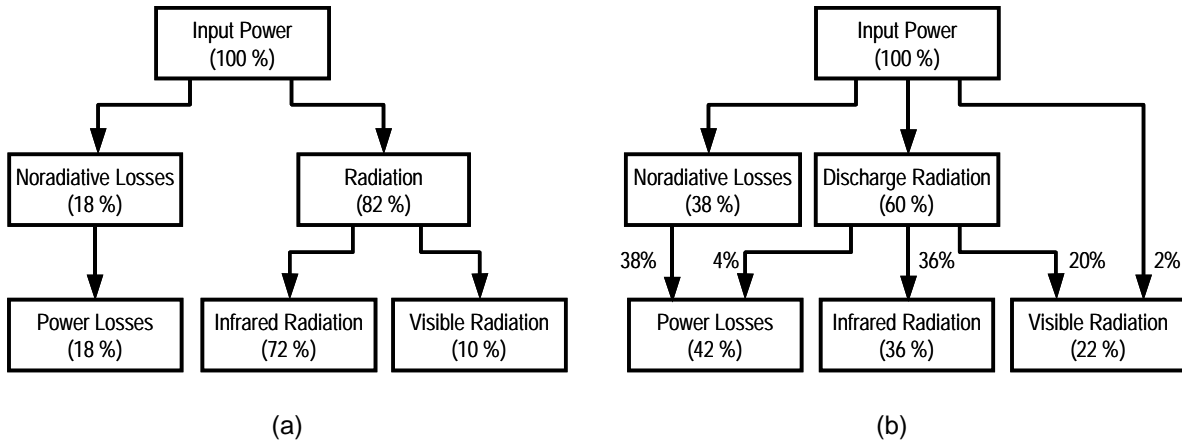

Figure 2. (a) Energy distribution of an incandescent lamp. About 10% of the energy is converted to light. (b) Energy distribution of a fluorescent lamp. About 22% of the energy is converted to light. Other discharge lamps have a similar percentage.

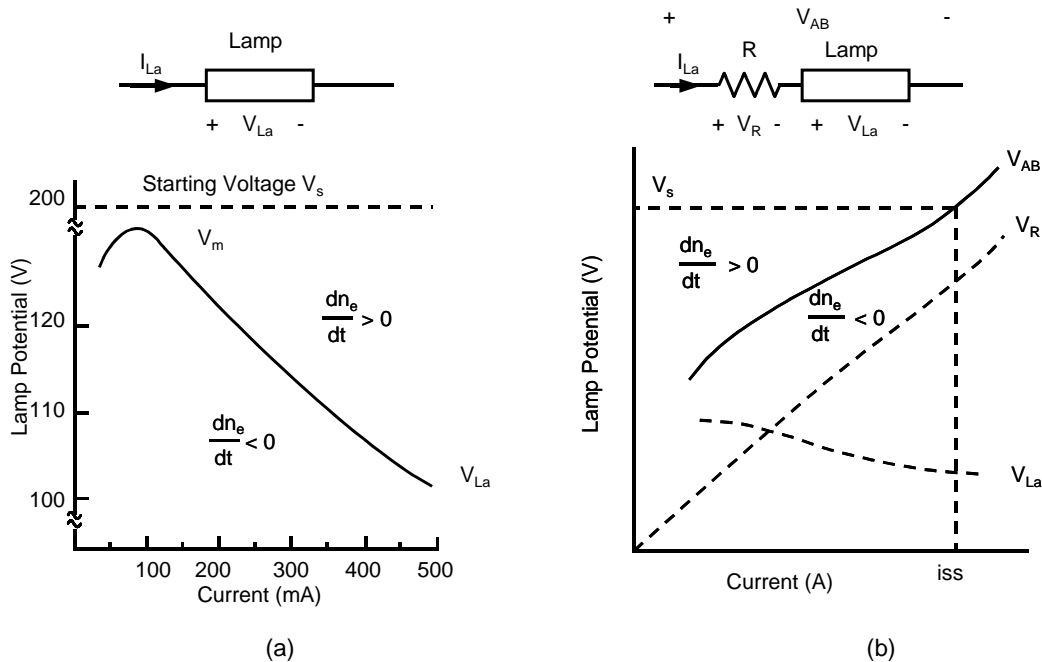

Figure 3. (a) Discharge potential drop versus current. (b) The effect of series resistance in stabilizing lamp current.

Upon application of a starting voltage to the lamp-resistor system and establishment of ionization, the operating point (i, v) is in the domain of positive dn_e/dt , increasing the lamp current until it reaches the point (i_{ss}, V_s). A further increase in current would move the operating point into the region of negative dn_e/dt , forcing the current back to i_{ss} . The resistor R helps to establish the stable operating point of the discharge lamp and acts as the ballast.

Electronic Ballast

Obviously, the resistive ballast incurs large power loss and significantly reduces the system efficiency. Fortunately, most discharge lamps are operated in alternating-current (AC) circuits so that inductive or capacitive impedance can be used to provide current limitation. AC operation also balances the wearing of two electrodes and maintains a longer lamp life. The inductor ballast represent the conventional ballasting approaches, and is known as magnetic ballasts.

Magnetic ballasts are operated in 50/60Hz line frequency. Every half line cycle, they re-ignite the lamp and limit the lamp current. Although magnetic ballasts have the advantages of low cost and high reliability, there exist at least three fundamental performance limitations due to the low-frequency operation. First of all, they are usually large and heavy. Second, the time constant of the discharge lamps is around one millisecond, which is shorter than the half line period (8.3ms for 60Hz line cycle), so the arc extinguishes at line voltage zero crossing, and then is re-ignited. Figure 4 shows the measured voltage and current waveforms of an F40T12 lamp operating at 60 Hz. After every line zero crossing, the lamp voltage waveform has a re-strike voltage peak; during the rest of the cycle, the voltage does not vary much. This causes two big problems: The lamp electrode wearing is significant, and the lamp's output light is highly susceptible to the line voltage, which results in an annoying visible flickering. Finally, there is no efficient and cost-effective way to regulate the lamp power.

These drawbacks led to studying the use of high-frequency AC current to drive the discharge lamps. High-frequency operation not only results in significant ballast volume and weight reduction, but also improves the performance of the discharge lamp. Figure 5 shows the measured voltage and current waveforms of the lamp operating with the same current level but at high frequency. The voltage and current waveforms are almost proportional with the same $v-i$ characteristic of a resistor, although this resistor is not linear and varies as a function of time and lamp current. The re-strike voltage peak no longer exists. The recombination of ions and electrons in the discharge is very low. No re-ignition energy is needed. The lamp electrodes also sustain the electron density during the transition from cathode to anode function, resulting in additional energy savings. Therefore, the gas discharge itself is more efficient in high-frequency operation, contributing to an increased efficacy. Figure 6 shows the curve of fluorescent lamp

Electronic Ballast

efficacy versus lamp operating frequency. It shows that the efficacy increases by about 10% when the operating frequency is above 20 kHz. Other discharge lamps have a similar characteristic. The high-frequency operation also makes the lamp start easily and reliably, and eliminates audible noise and flickering effect. In addition, due to the advances in power electronics, power regulation can be easily incorporated into the ballast, making intelligence and energy management feasible.

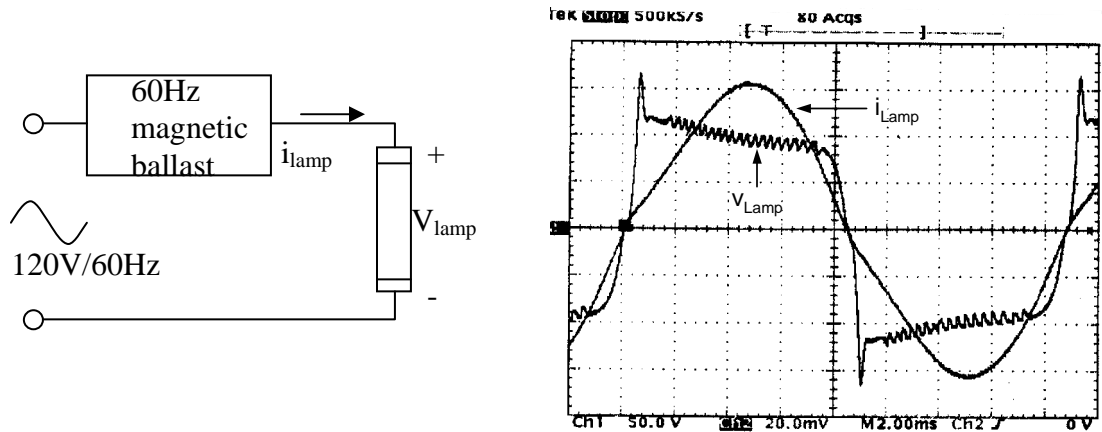

Figure 4. Measured lamp voltage and current waveforms at 60 Hz

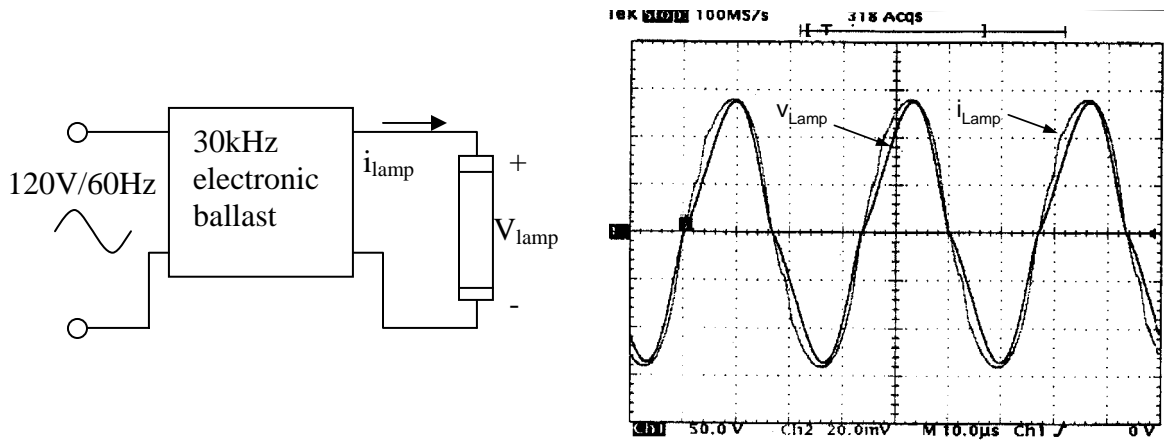

Figure 5. Measured lamp voltage and current waveforms at 30 kHz

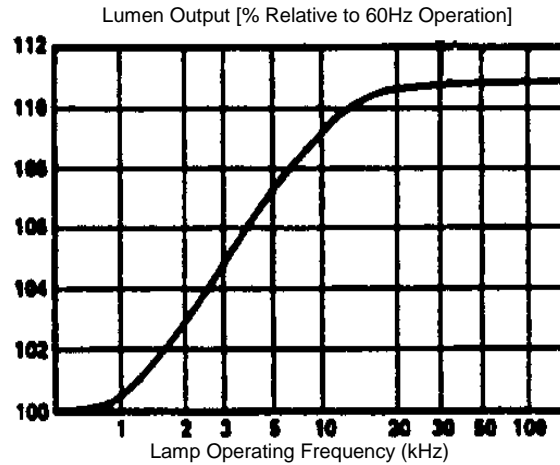

Figure 6. Fluorescent lamp efficacy versus lamp operating frequency

Essentially, the high-frequency electronic ballast is an AC/AC power converter, converting line-frequency power from the utility line to a high-frequency AC power in order to drive the discharge lamp. Figure 7 shows the circuit diagram of typical high-frequency electronic ballasts. The AC/DC rectifier contains four diodes and one bulk capacitor. This simple rectification scheme is still widely used because of its lower cost. However, it has very poor line side Power Factor (PF) and large Total Harmonic Distortion (THD). The low PF increases the reactive power and the large THD pollute the utility line. Figure 8a shows the line voltage and line current of typical electronic ballasts without any Power Factor Correction (PFC) circuitry. In order to solve this problem, rectifiers with PFC function is used such as Active PFC rectifier (eg. Boost converter) or Passive PFC circuitry (eg. LC filter). Figure 8b shows the line voltage and line current of the ballast with an Active PFC rectifier.

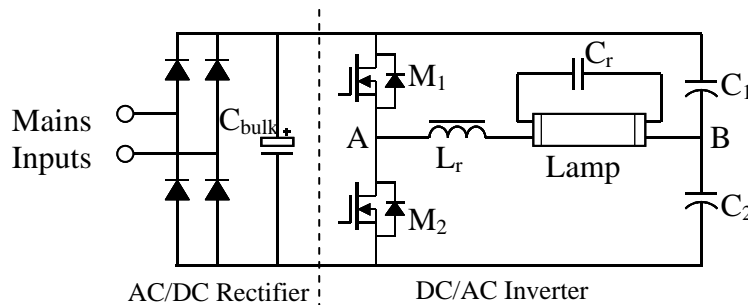

Figure 7. Typical topology for electronic ballasts: half-bridge series-resonant parallel-loaded ballast

Electronic Ballast

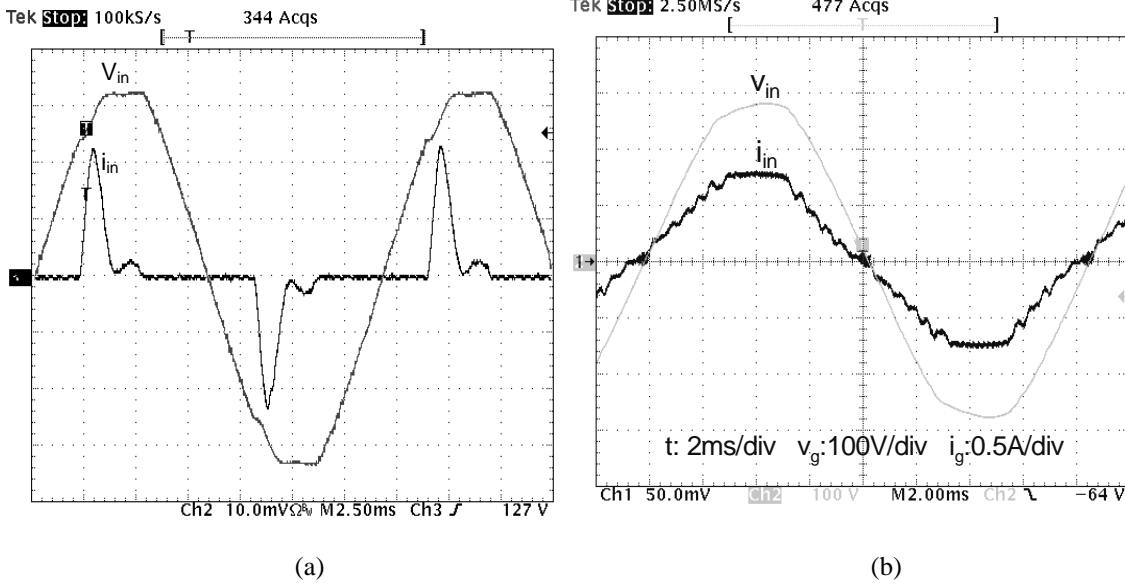

Figure 8 Line voltage and line current waveforms of electronic ballast w/ and w/o PFC circuit

The DC/AC inverter is a half-bridge series-resonant parallel-loaded converter. MOSFET M_1 and M_2 switch on and off complementarily with a fixed dead time, which generates a high frequency square waveform at point A. On the other hand, the voltage at point B is half of the bus voltage. If we take the resonant tank (L_r , C_r , and lamp) for consideration, a simplified circuit can be derived, as shown in Figure 9.

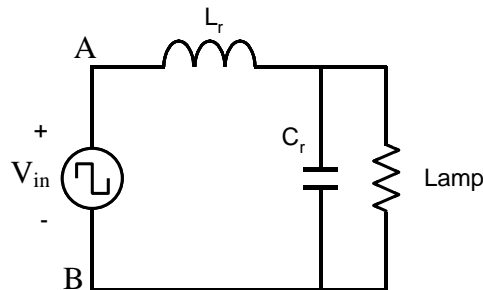

Figure 9. Resonant stage of voltage-fed ballasts

Before the lamp is ignited, the lamp resistance is very large so that it can be treated as open circuit. The gain curve of the lamp voltage over V_{in} as a function of the switching frequency is shown in Figure. 10. The lamp operating point goes from a to b, which means the switching frequency is decreasing and the lamp voltage is increasing. At point b, the lamp voltage reaches the lamp ignition level, so the lamp resistance drops quickly and the gain curve changes to the lower one. The operation point again moves from b to c, which is the steady state operation point.

Electronic Ballast

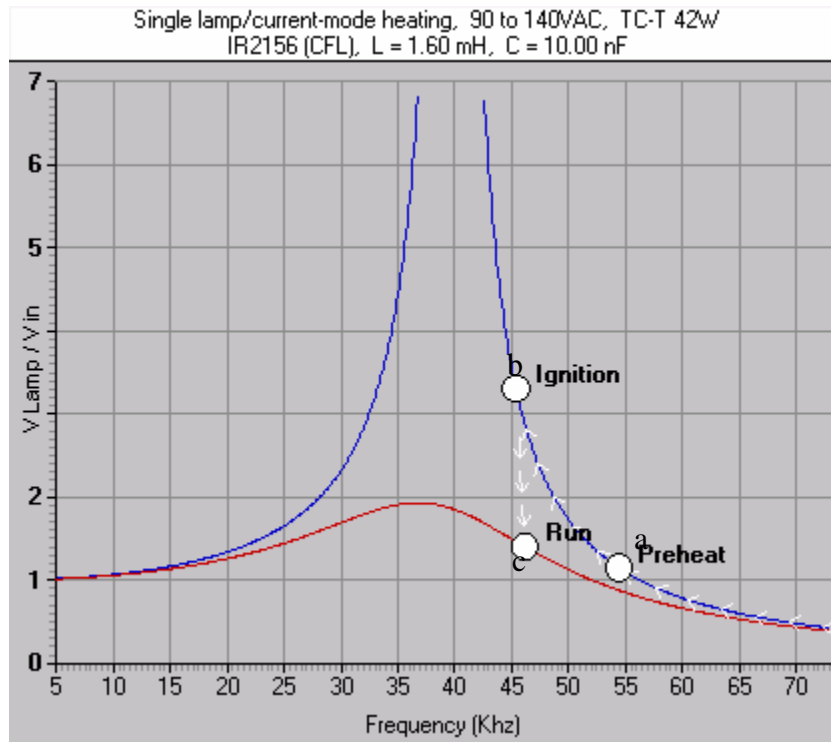

Figure 10. Gain curve of the lamp voltage over V_{in} as a function of the switching frequency

SUGGESTED PROCEDURE

For the realization of this experiment, you are going to use the IRPLCFL2 reference design board from International Rectifier. The lamp for this ballast board is F42QBX Compact Fluorescent Lamp (CFL) from General Electric. The board schematic is shown in Figure 11.

IRPLCFL2 Schematic Diagram

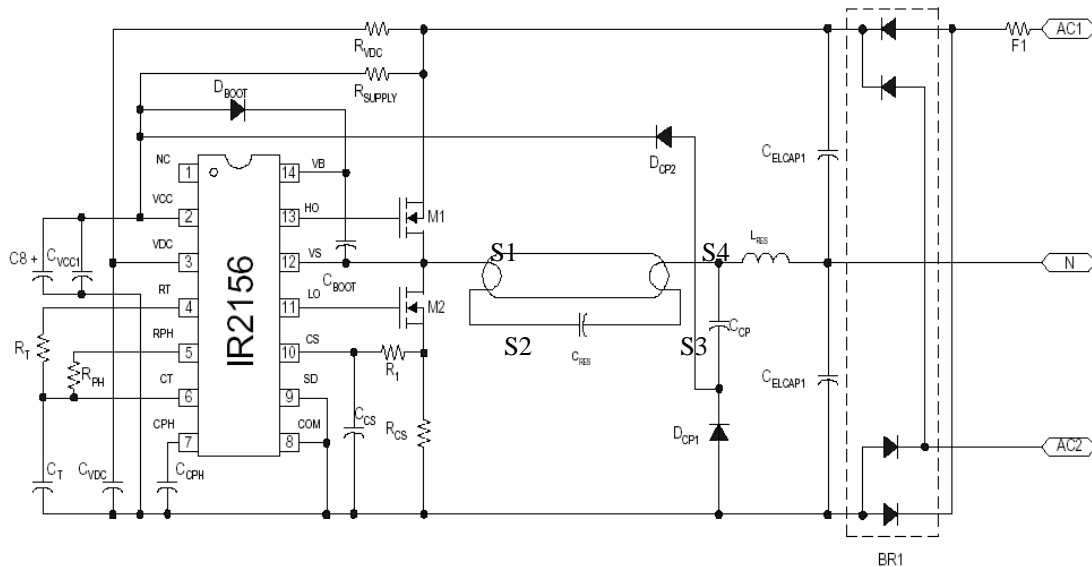

Figure 11. Schematic of the reference design

The given electronic ballast design can drive a 42 watt compact fluorescent lamp from a 120 or 230 volt AC line. The circuit was designed using the IR2156 Ballast driver IC which has following features:

- Fully programmable of preheat and run frequency;
- Fully programmable of dead time and over-current threshold;
- Built-in MOSFET drivers.

With a 120 volts AC line input (AC1-N), the voltage is rectified and doubled to provide a bus voltage of approximately 300 volts. Make sure that 120 volts AC line input is connected to the circuit. For safety issues, DO NOT touch the circuit board at any time when the circuit is running.

Electronic Ballast

For proper connections of the ballast and the lamp, please refer to the socket diagrams of the ballast and the lamp carefully (Figure 12, 13).

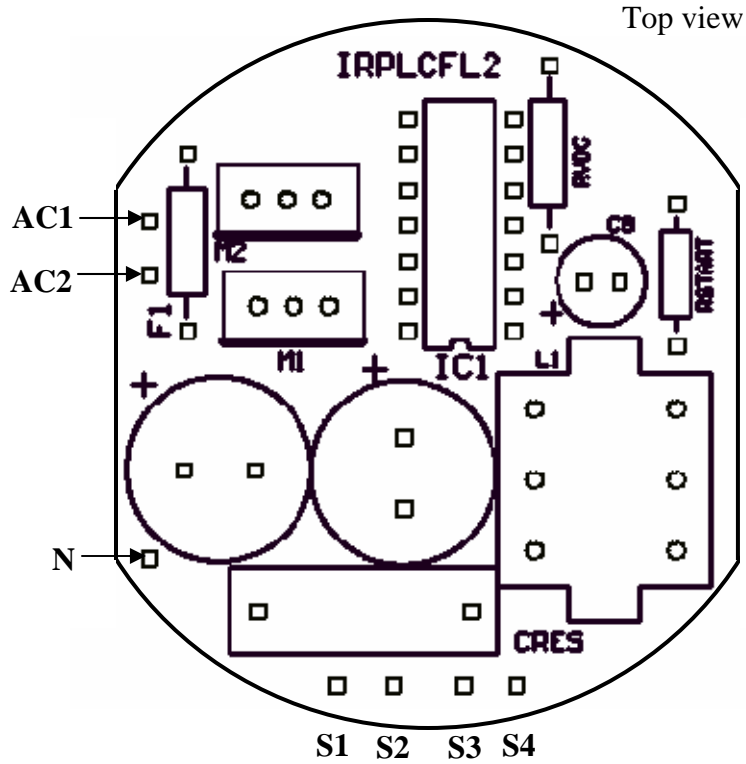

Figure 12. Socket diagram of the ballast

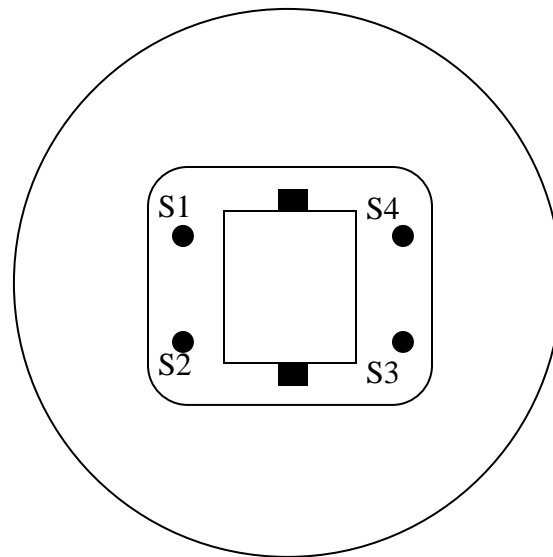

Figure 13. Socket diagram of the lamp

Electronic Ballast

Procedures:

1. The first part of the experiment is to understand the different efficacies of an incandescent lamp and a fluorescent lamp by comparing the luminance measured by a digital luxmeter. The unit of the luminance is lux, and one lux means one lumen per one square meter ($1 \text{ lux} = 1 \text{ lm/m}^2$). Connect the ballast/fluorescent lamp circuit as shown in Figure 14. Turn on the main switch K, and you will see the lamp ignited. Wait for at least 1 minute so that the lamp is at its steady state. Record the input power P_{in} . Use digital luxmeter to measure the luminance of the fluorescent lamp. Keep a constant distance between the lamp and the luxmeter (10cm is recommended) with the photometric probe facing the lamp directly as shown in Figure 15. Slightly adjust the angle between the probe and the lamp to get a maximum reading and record it down. Now turn off the lamp. There is one incandescent lamp setup for comparison. The lamp connection is shown in Figure 16. You can adjust the autotransformer so that the input power as indicated in the wattmeter is the same as which you recorded previously, P_{in} . Measure the luminance of the incandescent lamp using the same method you used for the fluorescent lamp.

2. The second part of the experiment is to understand the negative incremental impedance of the fluorescent lamp, which is the main reason why ballast is needed for the fluorescent lamp. You need to connect an autotransformer in the input side to adjust the input voltage to different values, as shown in Figure 17. Pay attention to the lamp current probe connection: make sure that wire A and wire B are both included by the probe, as shown in Figure 17. A multimeter is connected at the input side to monitor the input voltage of the ballast, V_{in} (Note: the multimeter should at “V~” position). Start by adjusting the autotransformer to let $V_{in}=120\text{V}$. Turn on the main switch K. Wait for at least 1 minute so that the lamp is at its steady state. Measure the RMS value of the lamp voltage and lamp current by the oscilloscope and record the data you get. Adjust the autotransformer to let $V_{in}=115\text{V}$. Redo the measurement and record the data. Keep decreasing the ballast input voltage in steps by 5volts until the lamp finally extinguished. Turn off the main switch K. Use the obtained data to plot a lamp voltage-current curve. It is important to mention that at no time should the ballast input voltage exceed 130V.

Electronic Ballast

3. The third part of the experiment is to understand the fluorescent lamp ignition mechanism that includes: Preheat, Ignition, and Run modes. Use the same connection as in Part2 (Figure 17). Adjust the ballast input voltage to 120V. Adjust the oscilloscope as following:

Time scale: 0.2 s/div

CH1: 0.5 A/div

CH2: 250 V/div

Trigger mode: Single, CH2, level: 50V

(Note: Make sure that the lamp has enough time to cool down) Turn on the main switch K, and wait for 30seconds until the scope displays the waveforms and stops. Turn off the circuit. Record the waveforms you have got.

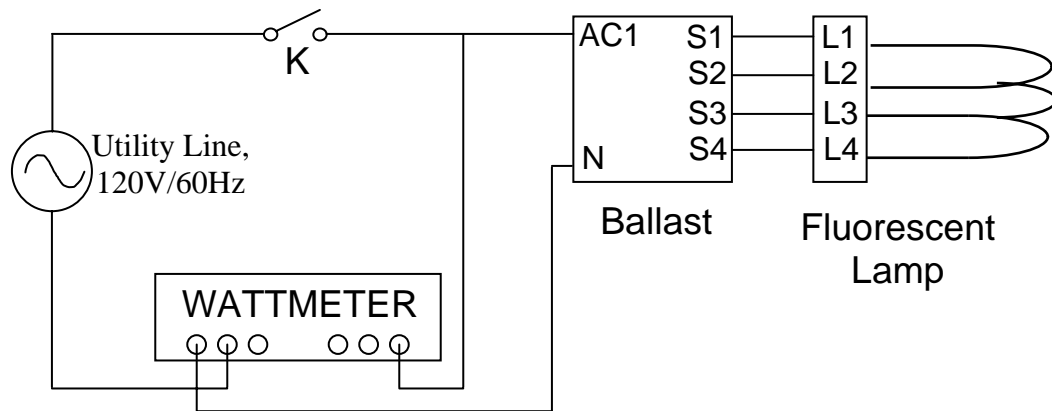

Figure 14 Fluorescent lamp/ballast setup diagram

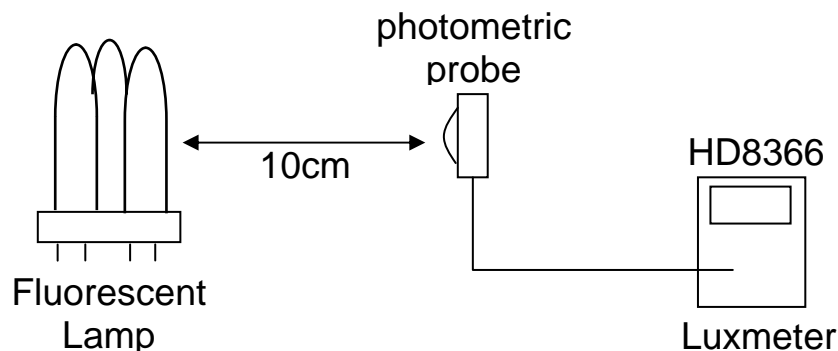

Figure 15 Diagram for luminance measurement

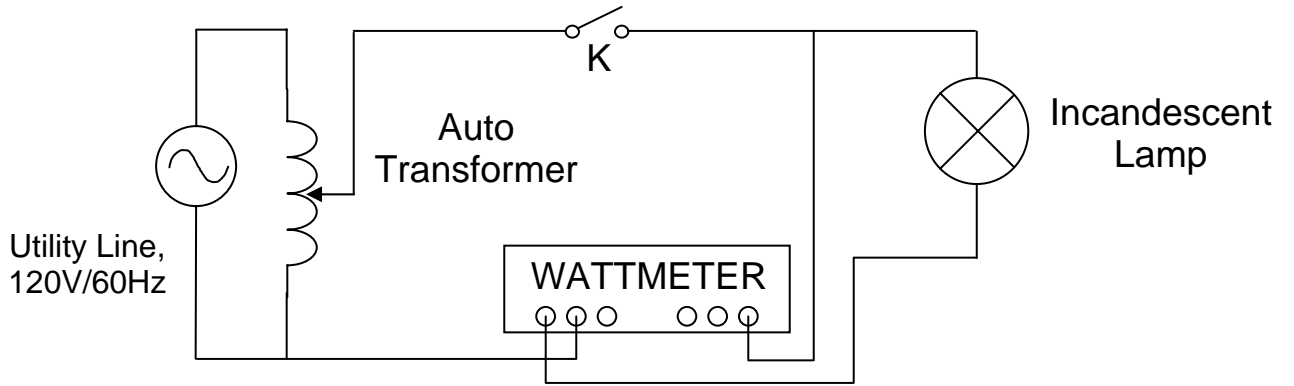

Figure 16 Incandescent lamp setup diagram

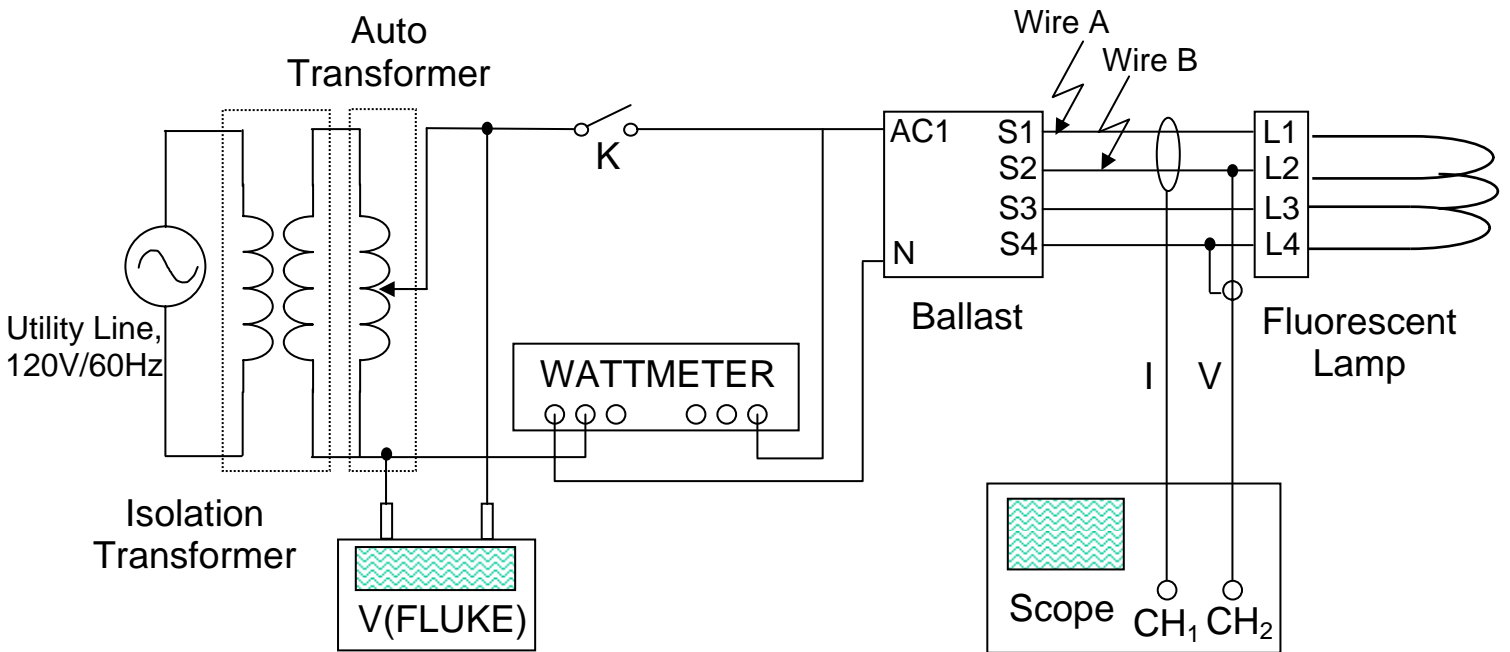
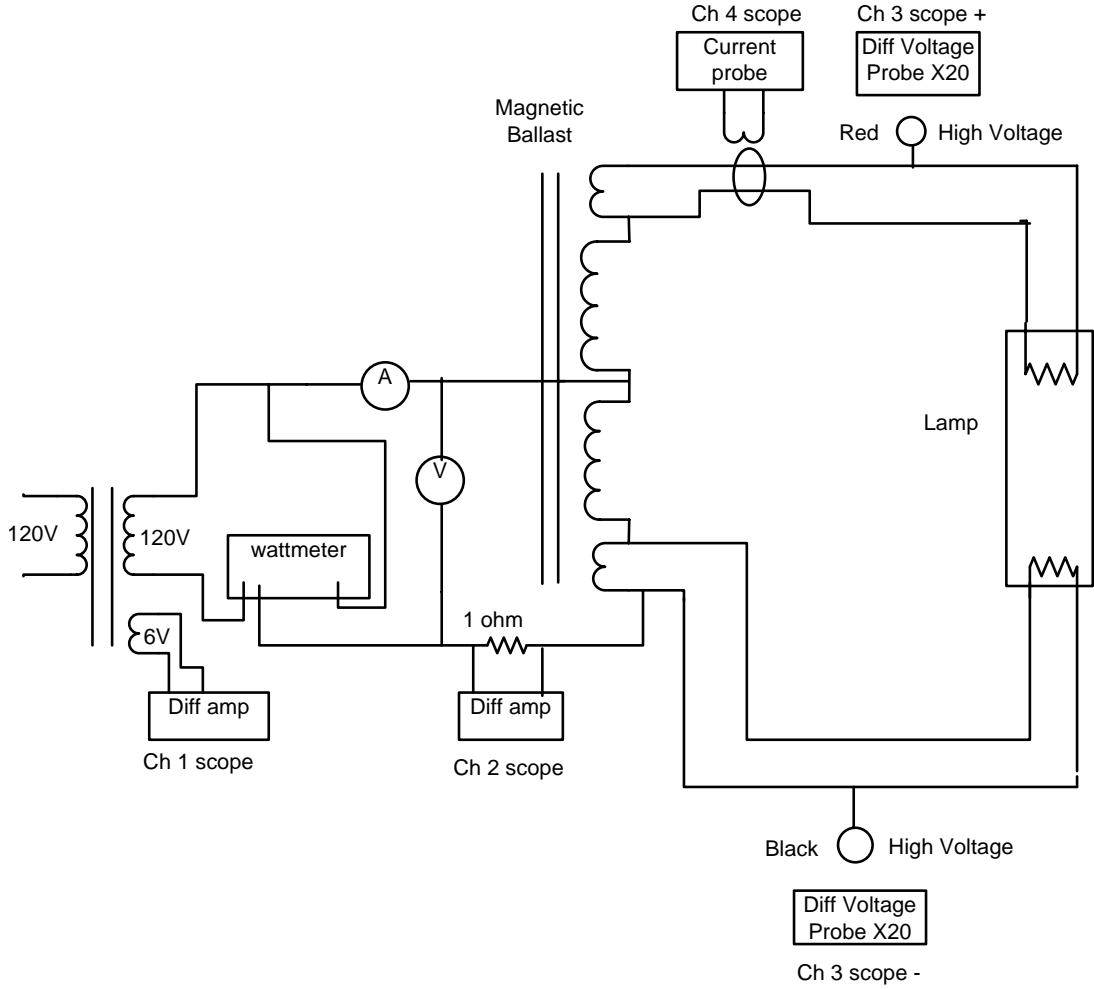

Figure 17 Setup diagram for Part2/Part3 of the experiment

Electronic Ballast



Setup for Magnetic Ballast

Electronic Ballast

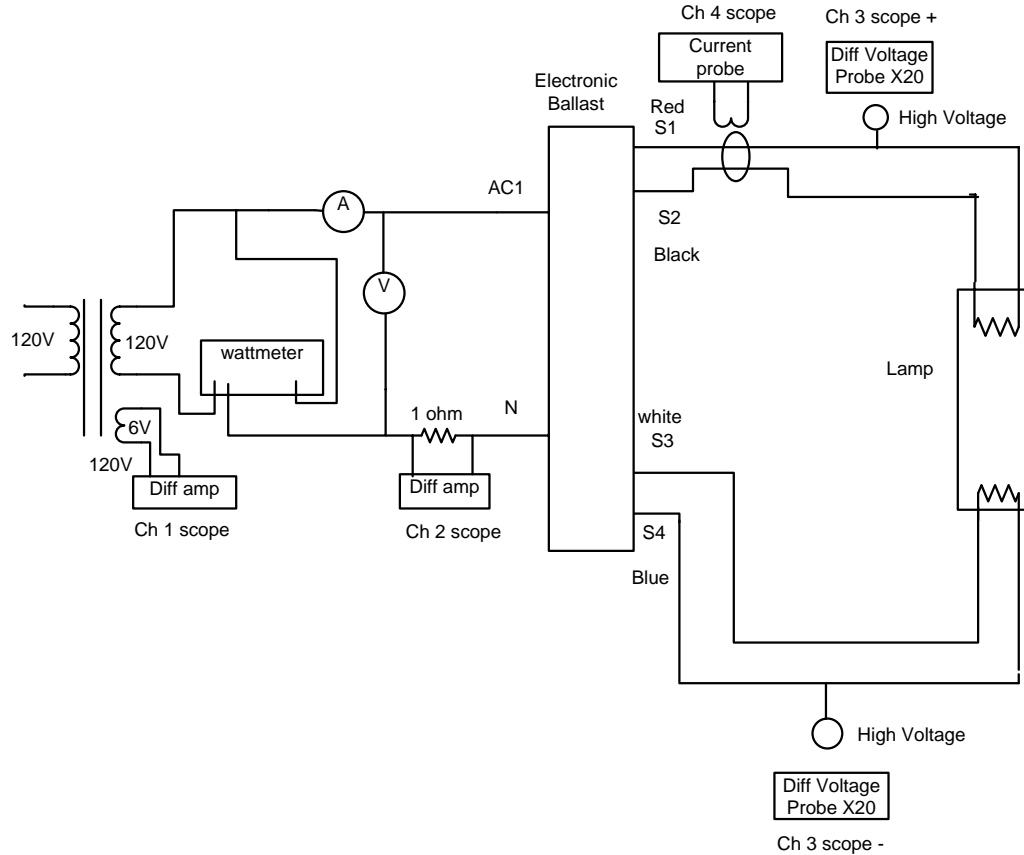

Setup for electronic ballast.

REPORT

1. Based on the luminance measurement data in Part1, estimate the total energy savings for a 42W fluorescent lamp during its lifetime compare with an incandescent lamp providing the same amount of lumens. The lifetime of the fluorescent lamp we use is about 12,000hrs.
2. With the data from Part2, plot the lamp voltage vs. lamp current curve. Calculate the lamp resistance at the rated input voltage (120V). Also calculate the incremental resistance ($dR=dV/dI$) from the curve. Explain the difference between a real resistor and a fluorescent lamp.

Electronic Ballast

3. Show the waveforms you got from Part3. Identify the three operating modes (Refer to figure 10).
4. Describe what will happen if the lamp is removed from the socket during its normal operation. Which kind of protection should be added into the ballast to deal with this fault condition?