

EE 2274
PRE-LAB EXPERIMENT 7
MOSFET BASICS

Pre Lab:

1. Simulate in PSpice a family of output characteristic curves for the IRF150 MOSFET.
 - a. Use a DC Sweep (Primary sweep) from 0 to 12 volts in 200mv increments to change the drain-source voltage (V_{ds}) of the MOSFET.
 - b. Use the Parametric sweep from 0 to 5 volts to change the gate to source voltage (V_{gs}) in 500 mv increments.
 - c. Run the simulation and then click on All and OK to display each curve.
 - d. Change the Y-axis to 1A by clicking on Plot → Axis Settings → Y axis → User Defined.
 - e. Find the voltage (V_{gs}) per step from your curves and the threshold voltage (V_{th}) for the IRF150. (Click right → information).

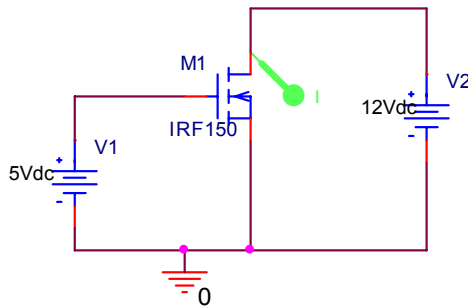

2. Build a four resistor bias circuit for a FET. Design the circuit such that $V_g=5V$, $V_{gs}=3V$, $V_{ds}=5V$, $I_d=10ma$, $I_{R3}=1ma$. Show your work.

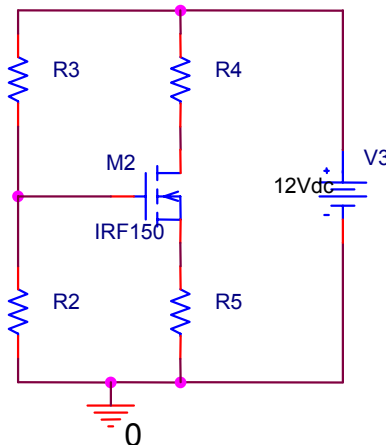

3. Simulate in PSpice the NMOSFET Inverter shown below. Instead of varying the drain-source voltage, vary the gate voltage. Use the DC sweep to vary the gate voltage V_{gs}

from 0 to 5 volts and plot this versus the 5 volt supply voltage. Turn your graph in.
What is the V_{th} voltage for the IRF150? How does this compare with $1e$?

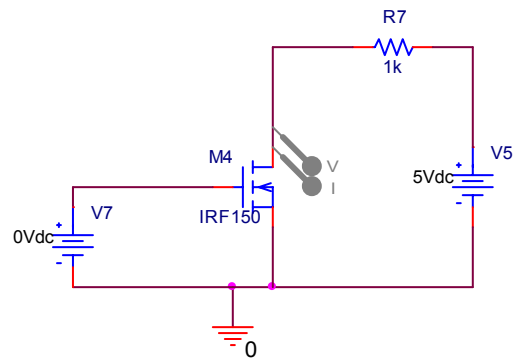

**LAB EXERCISE
EXPERIMENT #7
MOSFET BASICS**

Part I. Characteristic Curve

1. Perform the characteristics I-V curves for the 2N7000 MOSFET using the Tektronix curve tracer. Print curve.

Part II. Construct Circuit

1. Build the four resistor bias circuit that you designed in the Pre-Lab. Measure all of the currents going into the FET. Also measure all of the node voltages. Verify that your design works.

Part III. Inverter Circuit

1. Build the NMOSFET Inverter circuit that you used in the pre-lab to observe the switching behavior of the FET. Use a 1k hz square wave 5vpp, 2.5 V offset, (this will give you a 0-5 volt square wave). Use oscilloscope to verify your work.
 - a. What is the V_{th} for the 2N7000? (V_{gs} is where the MOSFET begins to conduct I_d)
 - b. What is the drain-source voltage (V_{ds} at turn-on and turn-off)?
 - c. What is the rise time and fall time of the MOSFETS drain-source voltage?
 - d. What is I_{ds} at turn-on and turn-off?

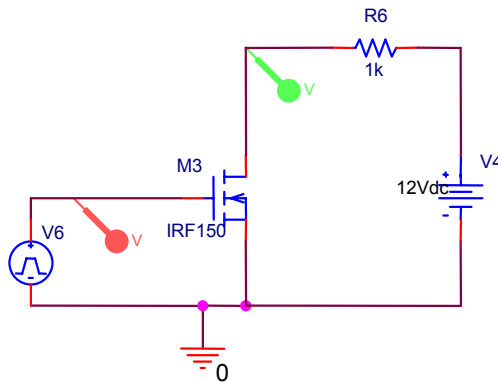

DATA SHEET
EXPERIMENT 7
MOSFET BASIC

Part I.

1. Turn in graph.

Part II.

- | | |
|------------------------------|-------------------------|
| 1. I_{ds} (measured) _____ | I_{ds} (design) _____ |
| V_{r2} (measured) _____ | V_{r2} (design) _____ |
| V_{r3} (measured) _____ | V_{r3} (design) _____ |
| V_{r4} (measured) _____ | V_{r4} (design) _____ |
| V_{r5} (measured) _____ | V_{r5} (design) _____ |
| V_{gs} (measured) _____ | V_{gs} (design) _____ |
| V_{ds} (measured) _____ | V_{ds} (design) _____ |

Part III.

- | | |
|------------------------------|-----------------------------|
| 1. V_{th} (measured) _____ | V_{th} (data sheet) _____ |
| 2. V_{ds} (off) _____ | V_{ds} (on) _____ |
| 3. T_r _____ | T_f _____ |
| 4. I_{ds} (on) _____ | I_{ds} (off) _____ |